



KONICA MINOLTA

SPECTROPHOTOMETER CM-2500d

High performance, low cost
portable spectrophotometer.



The essentials of imaging

Designed for versatility in various applications, the CM-2500d is a portable integrating sphere spectrophotometer incorporating Numerical Gloss Control.

Simultaneous measurement of SCI (specular component included) and SCE (specular component excluded).
Advanced Numerical Gloss Control.

Simultaneous measurement of SCI and SCE displays the data on the LCD in only 1.5 seconds. Unlike conventional spectrophotometers, there is no need to mechanically switch between SCI and SCE mode. This improves working efficiency and provides stable measured data since the measurement area does not shift when the mode is switched. And also Relativity Gloss Value can be displayed by using Numerical Gloss Control.



For plastics, paints, resins and consumer products

High reliability and long life.
Maintenance-free design.

The number of moving parts in the instrument is minimized through the introduction of numerical control technology. The CM-2500d can be used with confidence, since it has been developed, manufactured and calibrated to meet ISO 9001 requirements.

Allows measurement in any position.
Compact, lightweight, with an easy-to-operate navigation wheel and large LCD display.

The battery-powered small, light body allows the instrument to be placed in any position at the sample surface. The CM-2500d's large LCD display and its reverse display function provide easy reading, irrespective of which hand it is held in. Using your finger, the navigation wheel allows simple, user friendly operation.

(Turn) (Push)



For paints, plastics, automobiles, ceramics, architectural interiors, textile, paper, food etc.

Promotes accurate, consistent color communication.
Conforms to widely-accepted industry standards and allows measurements in all popular color spaces.

The optics use an integrating sphere to provide diffuse illumination/8-degree viewing system.

The CM-2500d conforms to all widely accepted standards including ISO, JIS, DIN, CIE and ASTM, and generates measurements in color spaces such as L*a*b*, Yxy, Munsell and CMC.

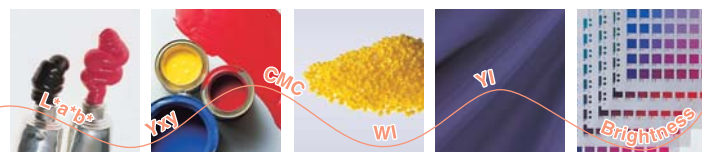

In various applications

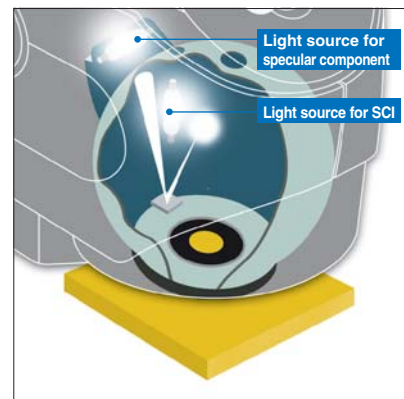

The LCD specifications are subject to change without prior notice.

• SCI is a method in which measurements are taken with the specular reflection included. For this reason, it minimizes influences of the surface condition of a sample, and is especially suitable for color quality control and Computer Color Matching.

• SCE is a method in which measurements are taken excluding the specular reflection. This type of measurement provides results similar to those observed visually.

Expanded LCD display (64 x 240 dots)
Displays large quantities of information (simultaneous display of SCI and SCE data etc.)

High-accuracy sensor
Measures at 10nm intervals for the full wavelength range. Excellent repeatability

Illuminated viewfinder

Easy-to-carry, compact and light body
670g (without batteries)

Numerical Gloss Control

Light source for specular component

Light source for SCI

Measures the target with high accuracy.
Easy-to-carry stylish body with an illuminated viewfinder.

The user can choose the most suitable measurement area for the target. The easy-to-carry body with the illuminated viewfinder enables the user to position the instrument on the target quickly and accurately.



For pharmaceuticals, cosmetics, printing, building materials, textiles, food etc.

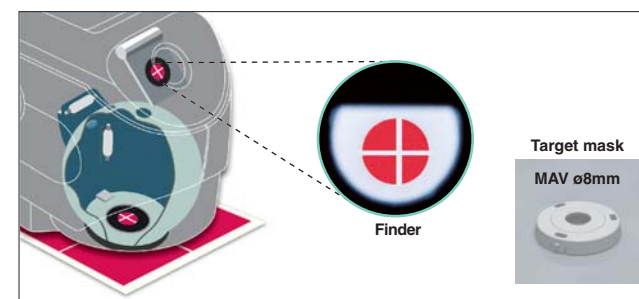

Powerful partnership between CM-2500d and SpectraMagic

Color Quality Control Software

SpectraMagic (Optional)

Supports Windows®98/2000, Windows NT®4.0

Consistent color communication. Since automatic setting of color difference tolerances is possible, accurate Pass/Fail information can be given to customers and manufacturers.

Enables color analysis from various viewpoints. Detailed, easy-to-see spectral graph.

Exports data to spreadsheet applications.

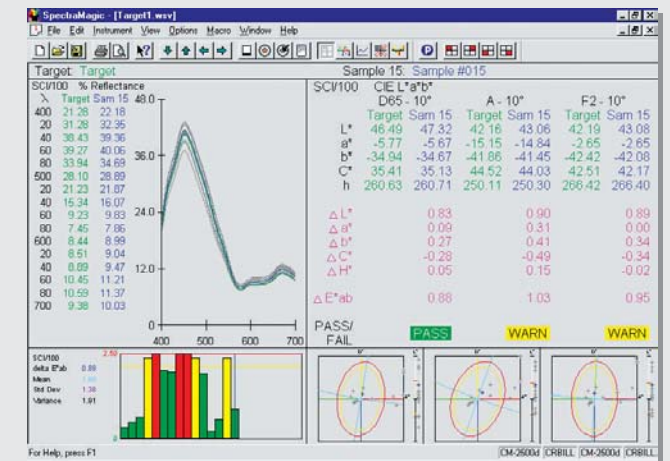

Procedures are displayed in the form of messages to eliminate in-process errors.
Task function by CM-2500d and SpectraMagic.

Measurement procedure can be downloaded to the CM-2500d from SpectraMagic. Since standard color difference for each part can be entered, human setting errors can be prevented.

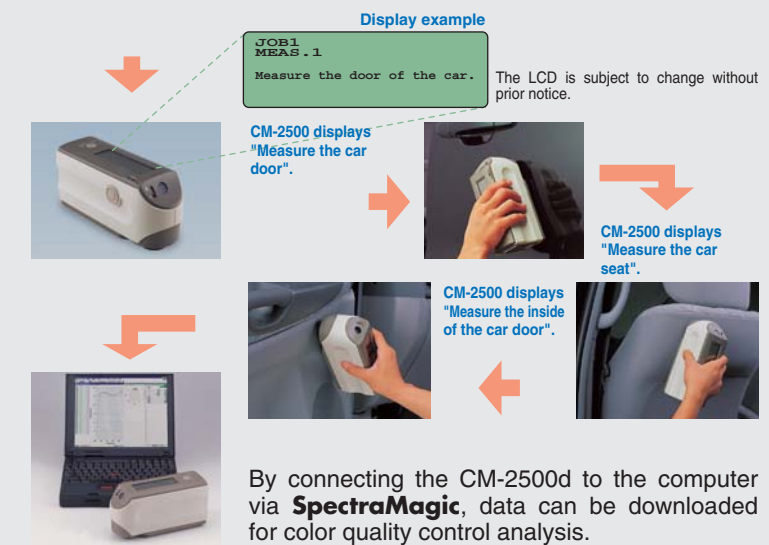

<Main Specifications>

Color space / Color difference scales	L*a*b*, L*c*h, L*u*v*, Hunter Lab, FMC-2, CMC, CIE-94, XYZ, Yxy
Color indices	Metamerism, Whiteness/Whiteness Difference, Yellowness/Yellowness Difference, Tint/Tint Difference, Brightness, opacity, Haze, Dominant Wavelength, Excitation Purity, Ganz WI, Ganz Tint
Observer Conditions	2°, 10°
Illuminant Conditions	A, C, D65, D50, D55, D75, F2, F6, F7, F8, F10, F11, F12, U50
Displays	Spectral plot, Color plot, Tolerance plot, Statistical report, Real color, K/S, Multi-view display
Tolerance Settings	Elliptical, Box, Pass / Warn / Fail

Microsoft®, Windows®, Windows®2000, Windows®98, Windows NT® are trademarks of Microsoft Corporation in the USA.

Specifications	
Illumination/viewing system	d/8 (diffuse illumination, 8-degree viewing), equipped with simultaneous measurement of SCI (specular component included)/SCE (specular component excluded) Conforms to CIE No.15, ISO 7724/1, ASTM E1164, DIN 5033 Teil7 and JIS Z8722 Condition C standard.
Sphere Size	ø52mm
Light-receiving element	Silicon photodiode array (dual 40 elements)
Spectral separation device	Diffraction grating
Wavelength range	360nm to 740nm
Wavelength pitch	10nm
Half bandwidth	Approx. 10nm
Reflectance range	0 to 175%, resolution: 0.01%
Light source	2 pulsed xenon lamps
Measurement time	Approx. 1.5 seconds (approx. 2 seconds for fluorescent measurement)
Minimum interval between measurements	3 seconds for SCI/SCE (4 seconds for fluorescent measurement)
Battery performance	Alkaline manganese: approx. 1000 measurements
Measurement/illumination area	MAV: ø8mm/ø11mm
Repeatability	Spectral Reflectance: Standard deviation within 0.1% (360 to 380nm within 0.2%) Colorimetric Value: Standard deviation within ΔE^*ab 0.04 (Measurement conditions: White calibration plate measured 30 times at 10-second intervals after white calibration was performed)
Inter instrument agreement	within ΔE^*ab 0.2 (MAV/SCI) based on 12BCRA Series II color tiles compared to values measured with master body.
Measurement mode	Single measurement/automatic averaging of multiple measurements (auto mode: 3, 5, 8 times/manual mode)
Interface	RS-232C standard
Observer	2/10 degrees (CIE 1931/2°, CIE 1964/10°)
Illuminant	A, C, D50, D65, F2, F6, F7, F8, F10, F11, F12 (simultaneous evaluation is possible using two light sources)
Display data	Spectral value/graph, colorimetric value, color difference value/graph, PASS/FAIL result
Color space/colorimetric data	L*a*b*, L*C*h, CMC (1:1), CMC (2:1), CIE94, Hunter Lab, Yxy, Munsell, XYZ, MI, WI (ASTM E313/CIE), Wt/Tint (CIE/Ganz & Griesser), YI (ASTM E313/ASTM D1925), ISO Brightness (ISO 2470), Density status A/T, L ₉₉ a ₉₉ b ₉₉ , L ₉₉ C ₉₉ h ₉₉
Data memory	700 (SCI/SCE as a set)
Tolerance Display	Tolerance for color difference (both box and elliptical tolerances can be set)
Power source	4 AA-size battery or AC adapter
Size (WxHxD)	69 x 96 x 193mm
Weight	Approx. 670g (without batteries)
Operating temperature/humidity range	5 to 40°C, relative humidity 80% or less (at 35°C) with no condensation
Storage temperature/humidity range	0 to 45°C, relative humidity 80% or less (at 35°C) with no condensation
Standard accessories	White calibration plate, Target mask ø8mm, RS-232C cable, AC adapter, AA-size battery (x4)
Optional Accessories	Hard case, Dust cover set, Dust cover, SpectraMagic (software), Zero calibration box

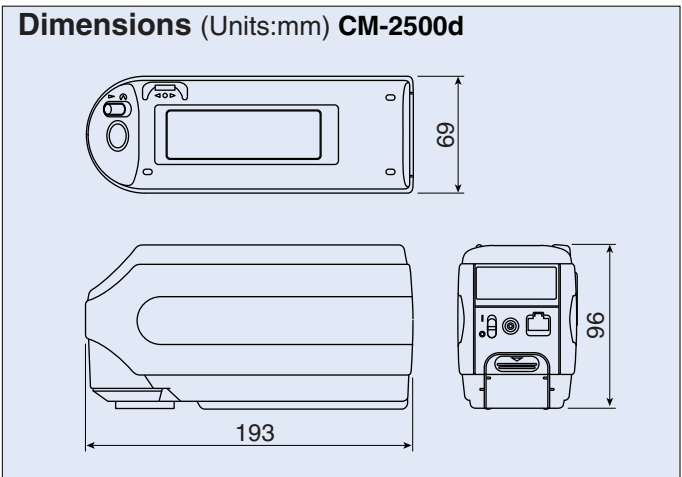
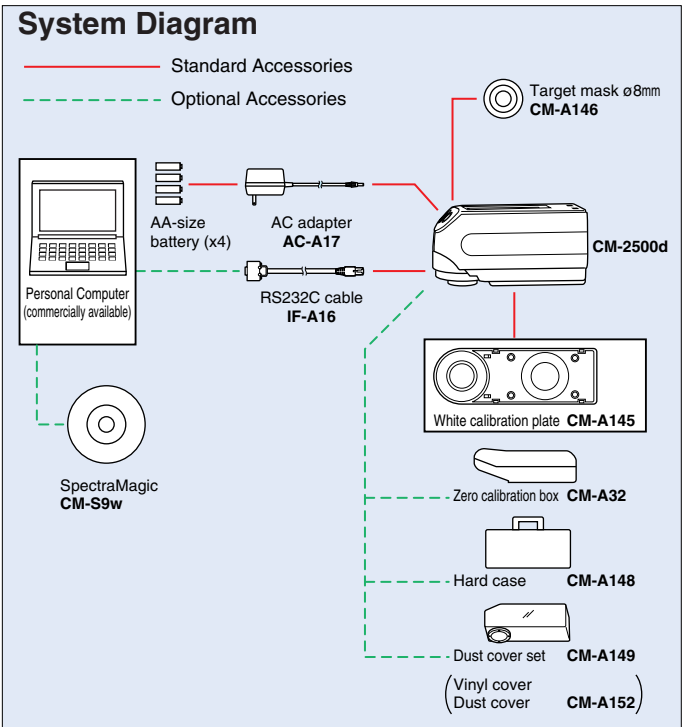

* The specifications and drawings given here are subject to change without prior notice.

Color control network by spectrophotometer

High inter-instrument agreement between the portable CM-2500d spectrophotometer and the desktop CM-3000 series make it easy to build a total color control network.

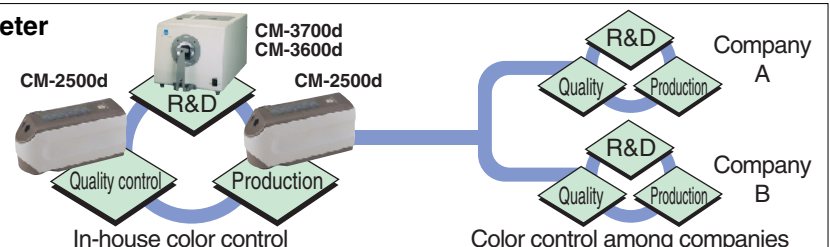

SAFETY PRECAUTIONS

To ensure correct use of the instrument, please adhere to the following.

- Before using the instrument, be sure to read the instruction manual.
- Always use the specified power. Use of inappropriate power may result in fire or electric shock.

The manufacturing center of Konica Minolta Sensing Inc. (Location: Aichi Pref., Japan) was approved by the British certification organization Lloyd's Register Quality Assurance for certification under the ISO 9001: 1994 international quality management system standards on March 3, 1995. Since its establishment in 1990, the center has carried out the development and production of precision instruments and associated application software for the measurement of color, light, and shape. Certification was awarded to the center's quality management system, including design, manufacturer, management of manufacture, calibration and servicing. Certification was carried over to the ISO 9001: 2000 standards in February, 2003.

KONICA MINOLTA SENSING, INC.

Konica Minolta Photo Imaging U.S.A., Inc.
Konica Minolta Photo Imaging Canada, Inc.
Konica Minolta Photo Imaging Europe GmbH
Konica Minolta Photo Imaging France S.A.S.
Konica Minolta Photo Imaging UK Ltd.
Konica Minolta Photo Imaging Austria GmbH
Konica Minolta Photo Imaging Benelux B.V.
Konica Minolta Photo Imaging (Schweiz) AG
Konica Minolta Business Solutions Italia S.p.A.
Konica Minolta Photo Imaging Svenska AB
Konica Minolta Photo Imaging (HK) Ltd.
Shanghai Office
Konica Minolta Photo Imaging Asia HQ Pte Ltd.
KONICA MINOLTA SENSING, INC. Seoul Office

3-91, Daisennishimachi, Sakai.Osaka 590-8551, Japan

725 Darlington Avenue, Mahwah, NJ 07430, U.S.A. Phone: 888-473-2656 (in USA), 201-529-6060 (outside USA) FAX: 201-529-6070
1329 Meyerside Drive, Mississauga, Ontario L5T 1C9, Canada Phone: 905-670-7722 FAX: 905-795-8234
Europaallee 17, 30855 Langenhagen, Germany Phone: 0511-740440 FAX: 0511-741050
Paris Nord II, 385, rue de la Belle-Etoile, B.P. 50077, F-95948 Roissy C.D.G. Cedex, France Phone: 01-49386550 / 01-30866161 FAX: 01-48638069 / 01-30866280
Precedent Drive, Rooksley Park, Milton Keynes United Kingdom Phone: 01-908200400 FAX: 01-908618662
Amalienstrasse 59-61, 1131 Vienna, Austria Phone: 01-87882-430 FAX: 01-87882-431
Postbus 6000, 3600 HA Maarssen, The Netherlands Phone: 030-2470860 FAX: 030-2470861
Riedstrasse 6, 8953 Dietikon, Switzerland Phone: 01-7403727 FAX: 01-7422350
Via Stephenson 37, 20157, Milano, Italy Phone: 02-39011-1 FAX: 02-39011-219
Solnastrandvägen 3, P.O.Box 9058 S-17109, Solna, Sweden Phone: 08-627-7650 FAX: 08-627-7685
Room 1818, Sun Hung Kai Centre, 30 Harbour Road, Wanchai, Hong Kong Phone: 852-34137508 FAX: 852-34137509
Rm 1211, Ruijin Building No.205 Maoming Road (S) Shanghai 20020, China Phone: 021-64720496 FAX: 021-64720214
10, Teban Gardens Crescent, Singapore 608923 Phone: +65 6563-5533 FAX: +65 6560-9721
801, Chung-Jin Bldg., 475-22, BangBae-Dong, Seocho-ku, Seoul, Korea Phone: 02-523-9726 FAX: 02-523-9729