



205 Westwood Ave  
Long Branch, NJ 07740  
1-877-742-TEST (8378)  
Fax: (732) 222-7088  
salesteam@Tequipment.NET

# HAKKO 936

SOLDERING STATION

## SOLDERING STATION

# Instruction Manual

●

Thank you for purchasing the HAKKO 936 Soldering Station.  
Please read this manual before operating the HAKKO 936.  
Store the manual in a safe, easily accessible place for future reference.

●

### Table of Contents

Packing List/Specifications .....	1
Precautions.....	2
Names of Parts .....	3
Setting up & Operating the HAKKO 936.....	3-4
Tip Care and Use	
Maintenance	
Calibrating the Iron Temperature.....	5
Tips .....	6
Troubleshooting Guide .....	7
Checking for breakage of the	
heating element and cord assembly.....	8-9
Parts List	
Station / Iron Holder.....	10
Iron.....	11
Wiring Diagram.....	11

# Packing List

Please check the contents of the HAKKO 936 package and confirm that all the items listed below are included.

HAKKO 936 Station.....	1
Soldering Iron (HAKKO 900 (S), 907 or 908) .....	1
HAKKO Iron Holder (With Cleaning Sponge) .....	1
Hex Wrench (1.5 mm,0.059 in.).....	1
Instruction Manual .....	1

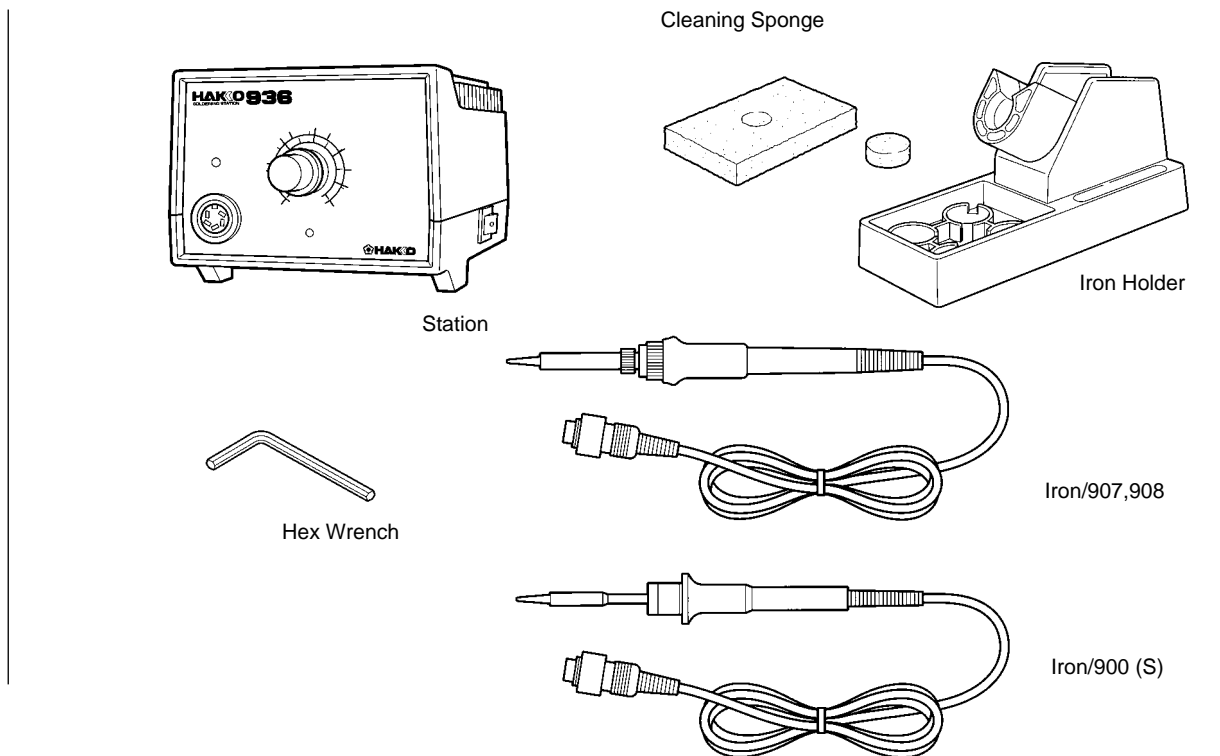

# Specifications

Name	HAKKO 936
Power Consumption	100,110,220-240V / 60W 120V / 65W

## Station

	936 Station / 936 Station ESD
Output Voltage	24V AC
Temperature Range	200°C~480°C/392°F~896°F
Dimensions	120(W)x93(H)x70(D)mm 4.7(W)x3.7(H)x6.7(D)in.
Weight (W/O Cord)	1,300g (2.9 lbs.)

## Soldering Iron

	900S 900S-ESD	907 907-ESD	908 908-ESD
Power Consumption	24V AC-50W		
Tip to Ground Resistance	Under 2Ω		
Tip to Ground Potential	Under 2mV (TYP. 0.6mV)		
Heating Element	Ceramic heater		
Cord Assembly	1.2m (4 ft.)		
Total Length (w/o Cord)	176mm (7 in.)	190mm (7.5 in.)	200mm (7.9 in.)
Weight (w/o Cord)	25g (0.06 lbs.)	44g (0.09 lbs.)	54g (0.12 lbs.)

- The tip temperature was measured using HAKKO 191 thermometer.
- Specifications and design subject to change without notice.

# Precautions

---

In this instruction manual, "warning" and "caution" are defined as follows.

## WARNING

 **WARNING:** Misuse may potentially cause death of, or serious injury to, the user.

 **CAUTION :** Misuse may potentially cause injury to the user or physical damage to the objects involved.

For your own safety, be sure to comply with these precautions.

## CAUTION

When the power is on, the tip temperature is between 200°C/392°F and 480°C/896°F.

Since mishandling may lead to burns or fire, be sure to comply with the following precautions.

- Do not touch the metallic parts near the Tip.
- Do not use the product near flammable items.
- Advise other people in the work area that the unit can reach a very high temperature and should be considered potentially dangerous.
- Turn the power off while taking breaks and when finished using the unit.
- Before replacing parts or storing the unit, turn the power off and allow the unit to cool to room temperature.

To prevent damage to the unit and ensure a safe working environment, be sure to comply with the following precautions.

- Do not use the unit for applications other than soldering.
- Do not rap the soldering iron against the work bench to shake off residual solder, or otherwise subject the iron to severe shocks.
- Do not modify the unit.
- Use only genuine HAKKO replacement parts.
- Do not wet the unit or use the unit when your hands are wet.
- The soldering process will produce smoke, so make sure the area is well ventilated.
- While using the unit, don't do anything which may cause bodily harm or physical damage.

# Names of Parts

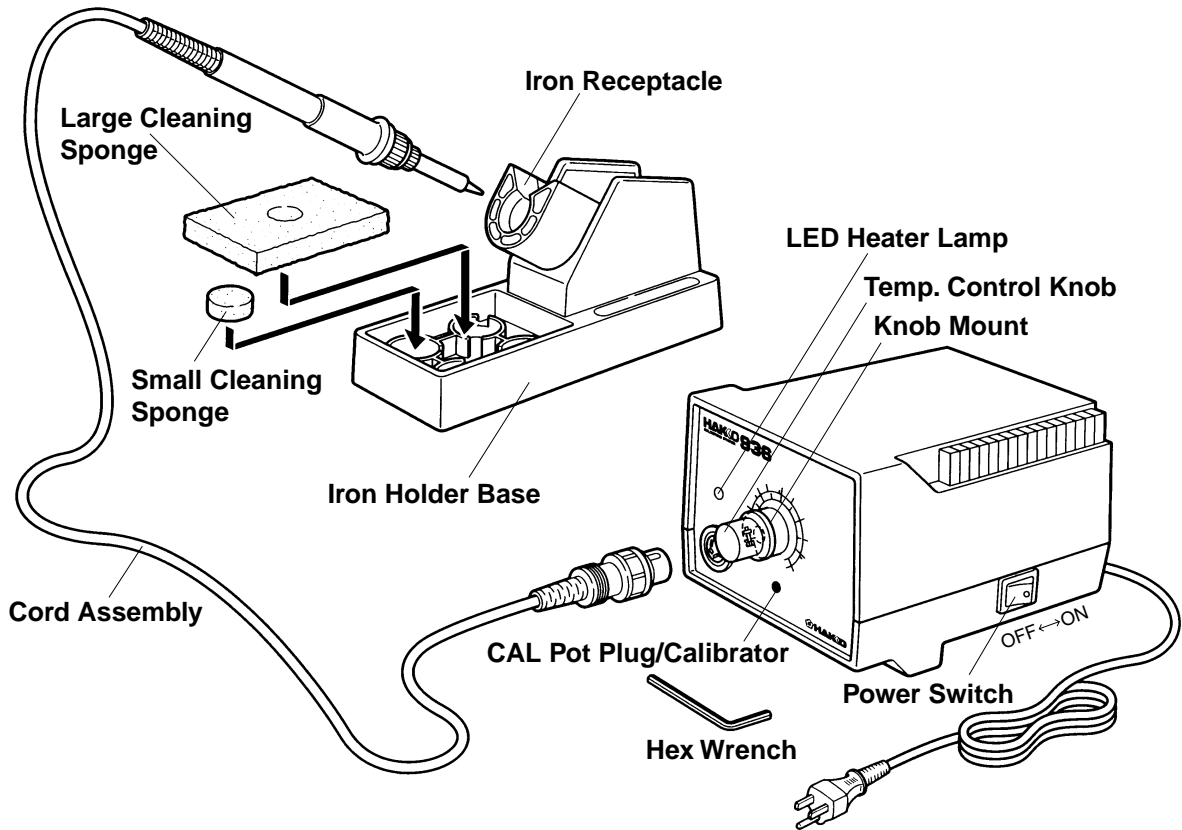

# Setting up & Operating the HAKKO 936

**⚠ CAUTION:** The sponge is compressed. It will swell when moistened with water. Before using the unit, dampen the sponge with the water and squeeze it dry. Failure to do so may result in damage to the soldering tip.

## A. Iron Holder

1. **Small Cleaning Sponge**  
Dampen the small cleaning sponge with water and then squeeze it dry. Place it in one of the 4 openings of the iron holder base.
2. **Add water** to approximately the level as shown. The small sponge will absorb water to keep the larger sponge above it wet at all times.  
\* The large sponge may be used alone (w/o small sponge & water).
3. **Dampen the large cleaning sponge** and place it on the iron holder base.

Note: The iron receptacles for the 900(S) and the 907/908 soldering irons are different. Be sure to use the proper one for each type of soldering iron. (Refer to Parts List).

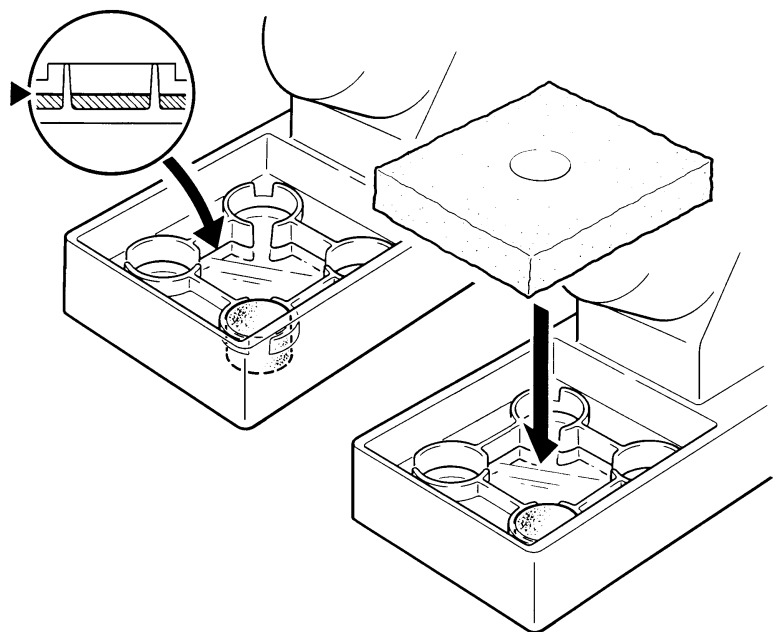

**⚠CAUTION** : Be sure to turn off the power switch before connecting or disconnecting the soldering iron. Failure to do so may damage the P.W.B.

## B. Connections

1. Connect the cord assembly to the receptacle.
2. Place the soldering iron in the iron holder.
3. Plug the power cord into the power supply. Be sure to ground the unit.

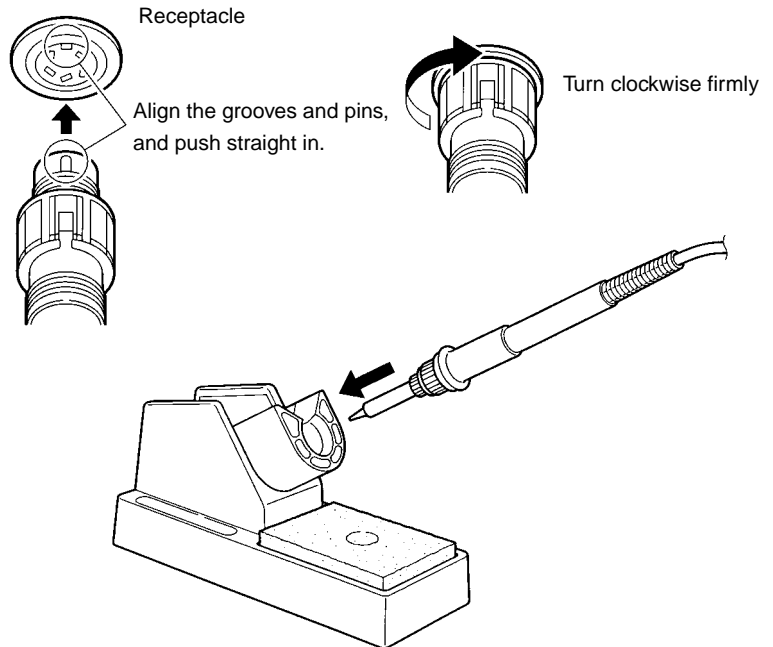

## C. Set the Temperature

1. Set the temperature control knob to the desired temperature.
2. Lock the knob.  
The HAKKO 936 station is equipped with a temperature control knob lock. After setting the desired temperature, tighten the hex nut on the underside of the knob mount using the supplied hex wrench. Turn the nut clockwise to tighten the knob lock.

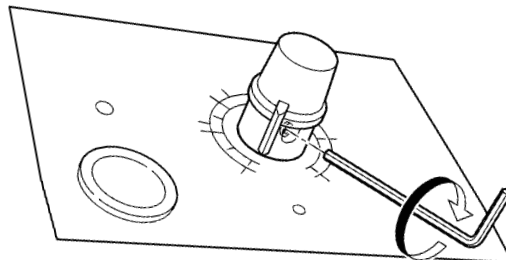

**⚠CAUTION** : •Don't overtighten the knob lock.  
•Don't attempt to turn the knob when the knob lock is on.

## D. Turn on the Power Switch.

The heater lamp blinks on and off when the tip temperature reaches the set temperature. The unit is now ready to perform soldering work.

For greater convenience, and soldering efficiency, two stations can be securely stacked as shown.

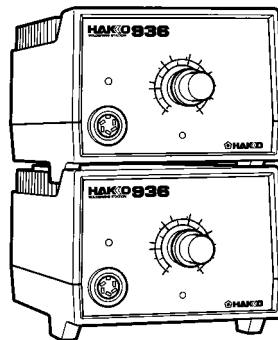

**⚠CAUTION** : The soldering iron must be placed in the iron holder when not in use.

# Tip Care and Use

---

## •Tip Temperature \_\_\_\_\_

High soldering temperatures can degrade the tip. Use the lowest possible soldering temperature. The excellent thermal recovery characteristics ensure efficient and effective soldering even at low temperatures. This also protects the soldered items from thermal damage.

## •Cleaning \_\_\_\_\_

Clean the tip regularly with a cleaning sponge, as oxides and carbides from the solder and flux can form impurities on the tip. These impurities can result in defective joints or reduce the tip's heat conductivity. When using the soldering iron continuously, be sure to loosen the tip and remove all oxides at least once a week. This helps prevent seizure and reduction of the tip temperature.

## •When Not in Use \_\_\_\_\_

Never leave the soldering iron sitting at high temperature for long periods of time, as the tip's solder plating will become covered with oxide, which can greatly reduce the tip's heat conductivity.

## •After Use \_\_\_\_\_

Wipe the tip clean and coat the tip with fresh solder. This helps prevent tip oxidation.

# Maintenance

---

## Inspect and Clean the Tip



**CAUTION** : Never file the Tip to remove oxide.

1. Set the temperature to 250°C (482°F).
2. When the temperature stabilizes, clean the tip with the cleaning sponge and check the condition of the tip.
3. If there is black oxide on the solder-plated portion of the tip, apply new solder (containing flux) and wipe the tip on the cleaning sponge. Repeat until the oxide is completely removed. Coat with new solder.
4. If the tip is deformed or heavily eroded, replace it with a new one.

# Calibrating the Iron Temperature

---

The soldering iron should be recalibrated after changing the iron, or replacing the heating element or tip.

- 1) Connect the cord assembly plug to the receptacle on the station.
- 2) Set the temperature control knob to 400°C (750°F).
- 3) Turn the power switch to 'ON' and wait until the temperature stabilizes. Remove the CAL potentiometer plug.
- 4) When the temperature stabilizes, use a straight-edge (-) screwdriver or small plus (+) screwdriver to adjust the screw (marked CAL at the station) until the tip thermometer indicates a temperature of 400°C (750°F). Turn the screw clockwise to increase the temperature and counterclockwise to reduce the temperature. Replace the CAL pot plug.

\* We recommend the HAKKO191/192 thermometer for measuring the tip temperature.

# Tips

The tip temperature will vary according to the shape of the tip. The preferred method of adjustment uses a tip thermometer. (See "Calibrating the Iron Temperature" on page 5.)

A less accurate method involves adjusting the temperature control knob according to the adjustment value for each tip.

**Example :** When using a 900M-T-H tip at 400°C (750°F),  
the difference between this tip and a 900M-T-B is -20°C (-36°F).  
Set the temperature control knob to 420°C (786°F).

Refer to the chart for the correct adjustment values.

## 907

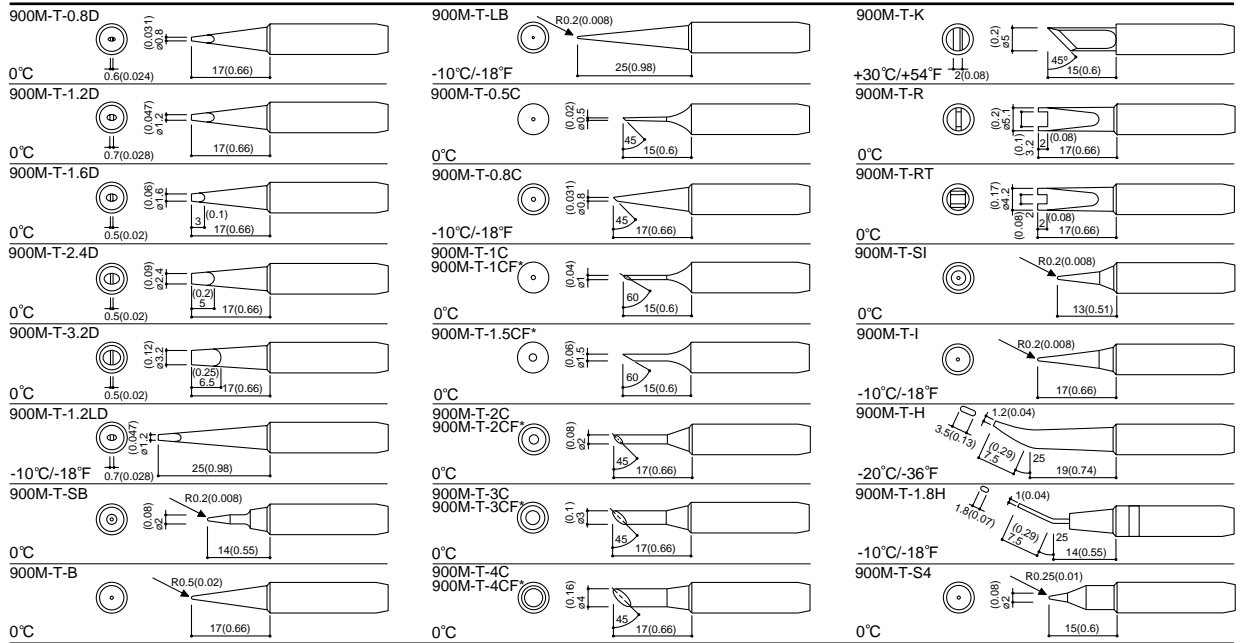

•900M tip Out Diam  $\phi$ 6.5

## 908 For heavy duty soldering HAKKO recommends the 908 iron with heavier tips.

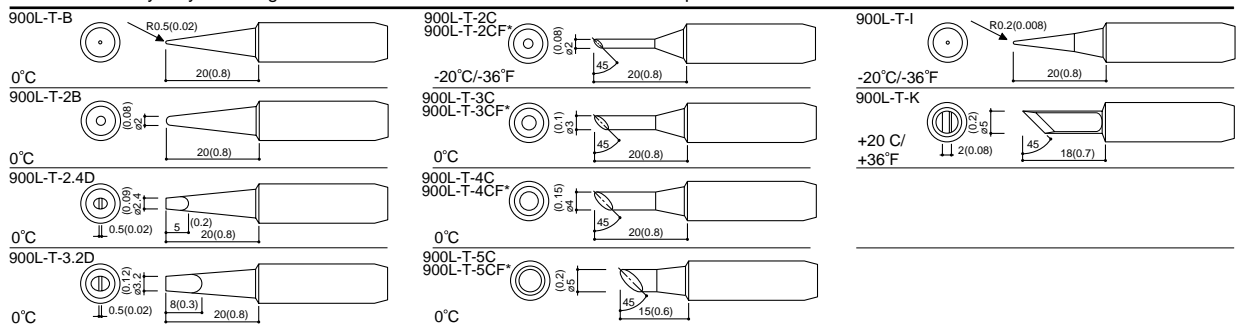

•900L tip Out Diam  $\phi$ 8.5

\*-These tips are tinned flat only.

## 900S For micro soldering HAKKO recommends the 900S iron with fine tips.

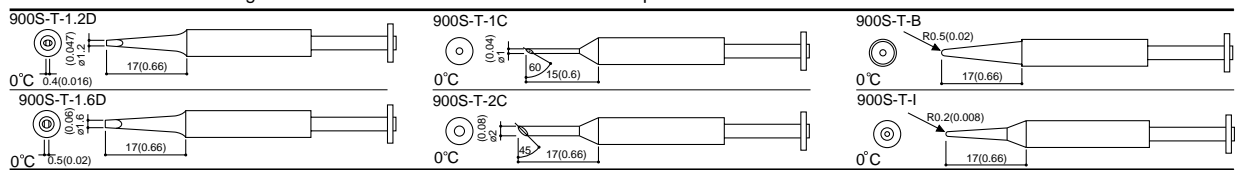

•900S Tip Out Diam  $\phi$ 5.8

# Troubleshooting Guide

---



**WARNING :** \* Disconnect the power plug before servicing.  
Failure to do so may result in electric shock.

\* If the power cord is damaged, it must be replaced by the manufacturer, its service agent or similarity qualified person in order to avoid personal injury or damage to the unit.

Problem 1.

**The heater lamp does not light up.**

**Check 1. Is the power cord and/or connecting plug disconnected ?**

- Connect it.

**Check 2. Is the fuse blown?**

- Determine why the fuse blew and eliminate the cause, then replace the fuse.
  - a. Is the inside of the iron short-circuited?
  - b. Is the grounding spring touching the heating element?
  - c. Is the heating element lead twisted and short-circuited?

Problem 2.

**The heater lamp lights up but the tip does not heat up.**

**Check 3. Is the soldering iron cord broken ?**

- Refer to 'Checking for breakage in the cord assembly.'

**Check 4. Is the Heating Element broken?**

- Refer to 'Checking for breakage in the heating element.'

Problem 3.

**The tip heats up intermittently.**

➡ **Check 3**

Problem 4.

**The tip is not wet.**

**Check 5. Is the tip temperature too high?**

- Set an appropriate temperature.

**Check 6. Is the tip clean?**

- Refer to 'Tip Care and Use'

Problem 5.

**The tip temperature is too low.**

**Check 7. Is the tip coated with oxide?**

- Refer to 'Inspect and clean the tip'

**Check 8. Is the iron calibrated correctly?**

- Recalibrate.

Problem 6.

**The tip can not be pulled off.**

**Check 9. Is the tip seized?**

**Is the tip swollen because of deterioration?**

- Replace the tip and the heating element.

Problem 7.

**The tip doesn't hold the desired temperature.**

➡ **Check 8**



# Checking for breakage of the heating element and cord assembly

Disconnect the plug and measure the resistance value between the connecting plug pins as follows.

If the values of 'a' and 'b' are outside the above value, replace the heating element (sensor) and/or cord assembly. Refer to Procedures 1 and 2.

If the value of 'c' is over the above value, remove the oxidization film by lightly rubbing with sand-paper or steel wool the points shown below.

a	Between pins 4&5 (Heating Element)	2.5 - 3.5Ω(Normal)
b	Between pins 1&2 (Sensor)	43 - 58Ω(Normal)
c	Between pin 3&Tip	Under 2Ω

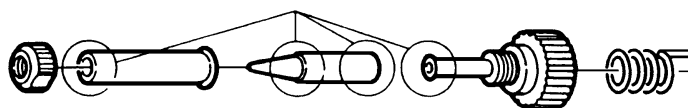
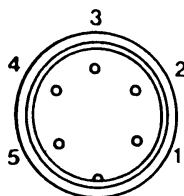

Disassembling the 907/908

## 1. Broken Heating Element

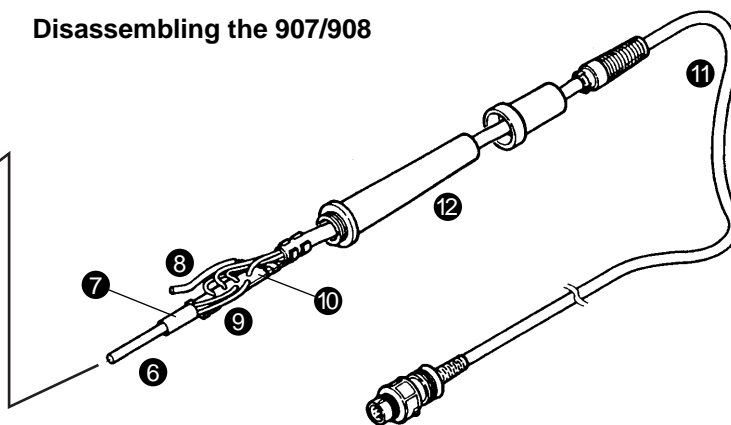
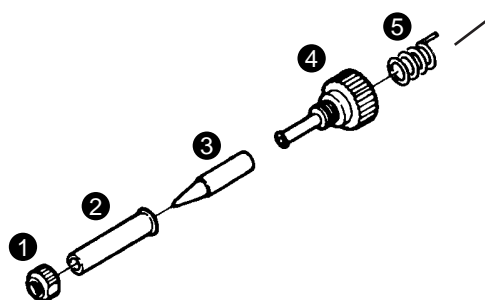

Heating Element (Red)      Sensor (Blue)



1. Turn the nut (1) counterclockwise and remove the tip enclosure (2), the tip (3).
2. Turn the nipple (4) counterclockwise and remove it from the iron.
3. Pull both the heating element (6) and the cord assembly (11) out of the handle (12). (Toward the tip of the iron.)
4. Pull the grounding spring (5) out of the D-sleeve.

Measure when the heating element is at room temperature.

1. Resistance value of heating element (RED) 2.5 - 3.5Ω
2. Resistance value of sensor (BLUE) 43 - 58Ω

If the resistance value is not normal, replace the heating element.

(Refer to the instructions included with the replacement part.)

After replacing the Heating Element,

1. Measure the resistance value between 1) pins 4 & 1 or 2) pins 5 & 1 or 2. If it is not ∞, the heating element and sensor are touching. This will damage the P.W.B.
2. Measure the resistance value 'a', 'b', and 'c' to confirm that the leads are not twisted and that the grounding spring is properly connected.

### Disassembling the 900S

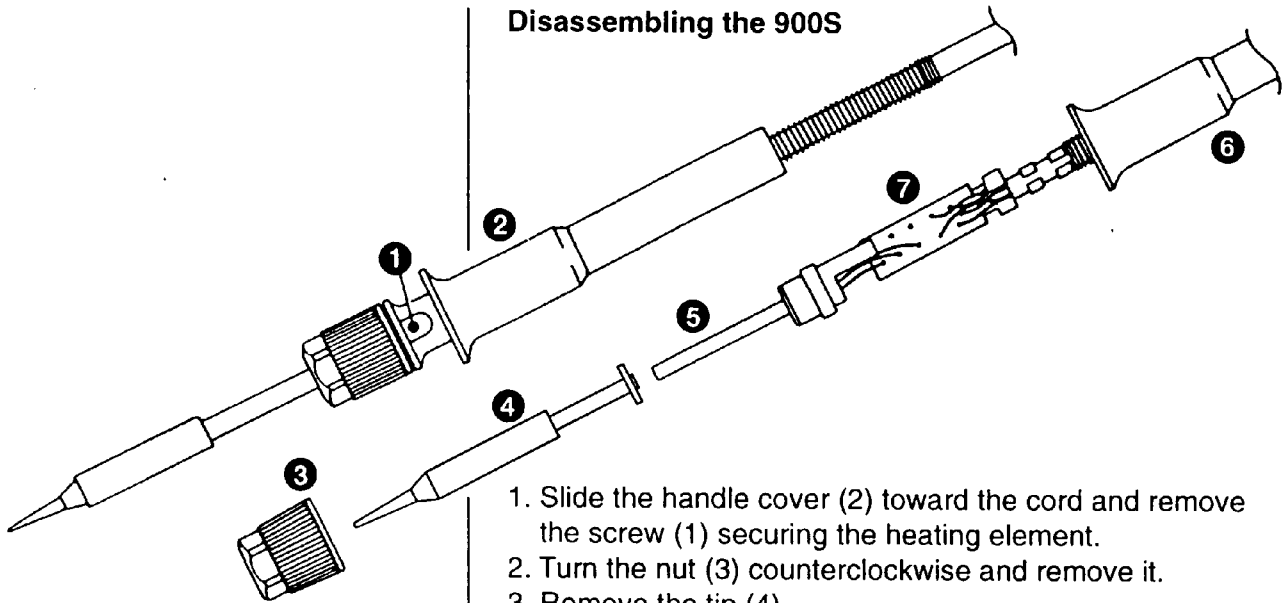

1. Slide the handle cover (2) toward the cord and remove the screw (1) securing the heating element.
2. Turn the nut (3) counterclockwise and remove it.
3. Remove the tip (4).
4. Pull both the heating element (5) and the cord toward the tip of the iron and out of the handle (6).

Measure the resistance values at the sensor and the heating element of the terminal board.

The resistance value should be the same as for the 907, 908. To replace the heating element, refer to the instructions included with the replacement part.

## 2. Broken Soldering Iron Cord

There are two methods of testing the soldering iron cord.

1. Turn the unit ON and set the temperature control knob to 480°C (896°F). Then wiggle and kink the iron cord at various locations along its length, including in the strain relief area. If the LED heater lamp flickers, then the cord needs to be replaced.

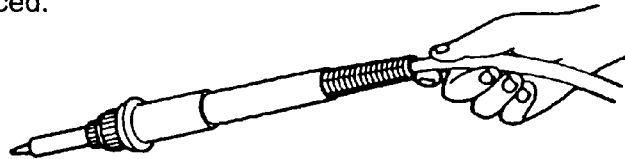

**CAUTION** : The LED heater lamp will flicker even with a normal Iron cord if the temperature reaches 480°C (896°F).

2. Check the resistance between the pin of the plug and the wire on the terminal.  
Pin 1: Red Pin 2: Blue Pin 3: Green Pin 4: White Pin 5: Black  
The value should be 0Ω. If it is greater than 0Ω or is ∞, the cord should be replaced.

## 3. Replacing the Fuse

Refer to the drawing in the replacement parts section of this manual. Desolder the blown fuse and remove it. Solder on a new one.

# Parts List (Station/Iron Holder)

Note: Spare or repair parts do not include mounting screws, if they are not listed on the description. Screws must be ordered separately.

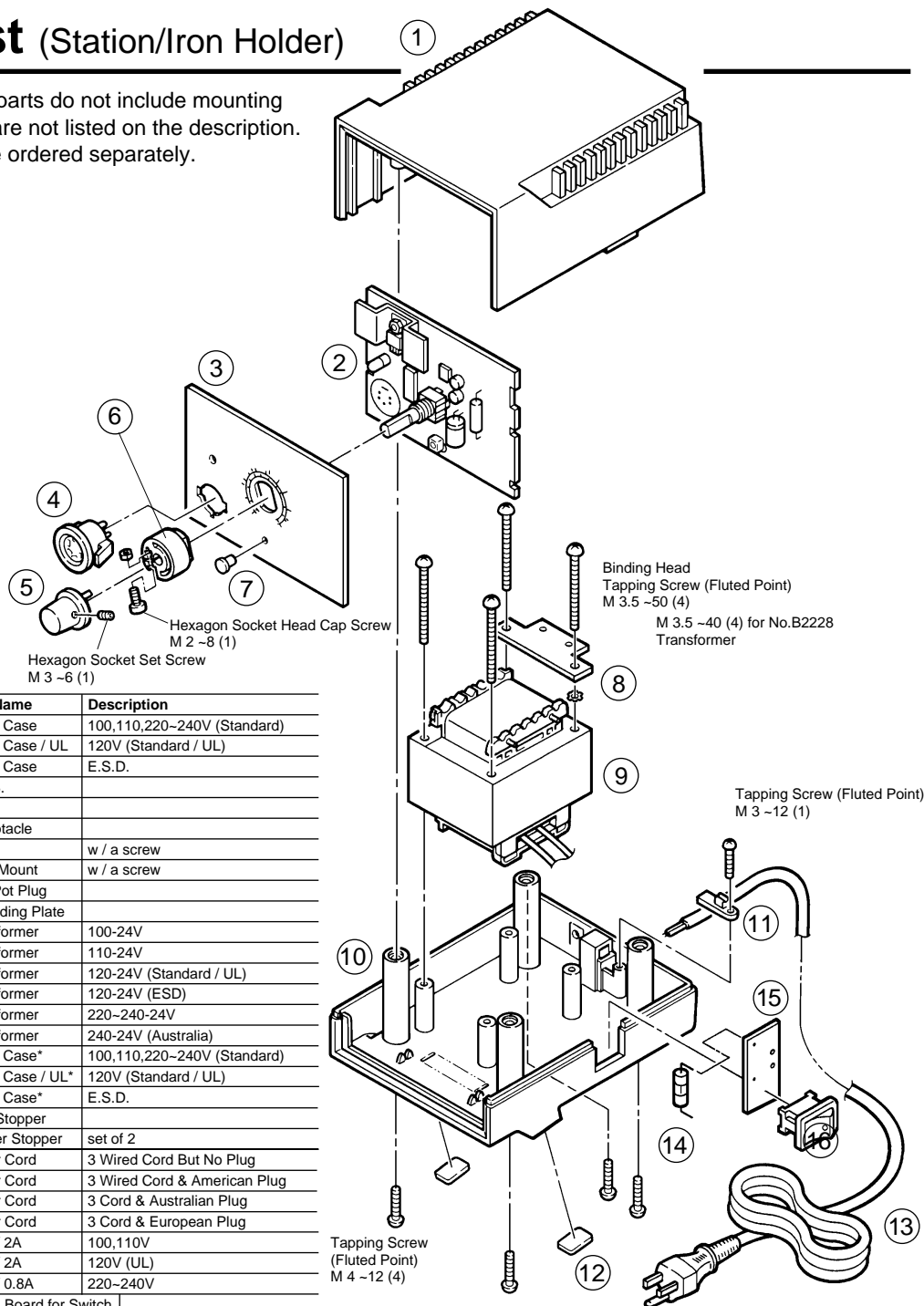

Item No.	Part No.	Part Name	Description
1	B2048	Upper Case	100,110,220-240V (Standard)
	B2225	Upper Case / UL	120V (Standard / UL)
	B2001	Upper Case	E.S.D.
2	B2229	P.W.B.	
3	B2003	Panel	
4	B2006	Receptacle	
5	B2004	Knob	w / a screw
6	B2005	Knob Mount	w / a screw
7	B2018	CAL Pot Plug	
8	B2227	Grounding Plate	
9	B2011	Transformer	100-24V
	B2012	Transformer	110-24V
	B2228	Transformer	120-24V (Standard / UL)
	B2013	Transformer	120-24V (ESD)
	B2014	Transformer	220-240-24V
	B2088	Transformer	240-24V (Australia)
10	B2000	Lower Case*	100,110,220-240V (Standard)
	B2226	Lower Case / UL*	120V (Standard / UL)
	B2002	Lower Case*	E.S.D.
11	B2015	Cord Stopper	
12	B2016	Rubber Stopper	set of 2
13	B1318	Power Cord	3 Wired Cord But No Plug
	B1319	Power Cord	3 Wired Cord & American Plug
	B2042	Power Cord	3 Cord & Australian Plug
	B2043	Power Cord	3 Cord & European Plug
14	B2007	Fuse / 2A	100,110V
	B2224	Fuse / 2A	120V (UL)
	B2008	Fuse / 0.8A	220-240V
15	B2103	Wiring Board for Switch	
16	B1084	Power Switch	
17	B2017	Hex Wrench	

\*w / Rubber Stopper

Item No.	Part No.	Part Name	For
1	C1141	Iron Holder	900S
	C1142	Iron Holder	907,908
2	B2020	Iron Receptacle	900S
	B2021	Iron Receptacle	907,908
3	B2019	Iron Holder Base	900S,907,908
4	A1042	Cleaning Sponge	900S,907,908

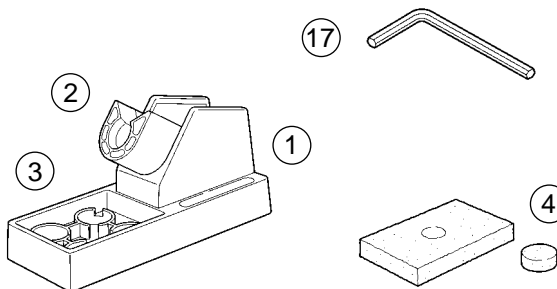

# Parts List (Iron)

## 900S

Item No.	Part No.	Part Name	Description
1	900S-006	Nut	
	900S-006S	Nut	E.S.D.
2		Soldering Tip	See. P.6
3	A1322	Heating Element	Old part No.900S-H
4	900S-101	Terminal Board	w/Cord Stopper
5	900S-001	Handle	w/Handle Cover
	900S-001S	Handle	w/Handle Cover, E.S.D.
6	900S-034	Handle Cover	
	900S-034S	Handle Cover	E.S.D.
7	900S-010	Cord Bushing	(Not shown)
8	900S-039	Cord Asse'y	(Not shown)
	900S-039S	Cord Asse'y	E.S.D. (Not shown)

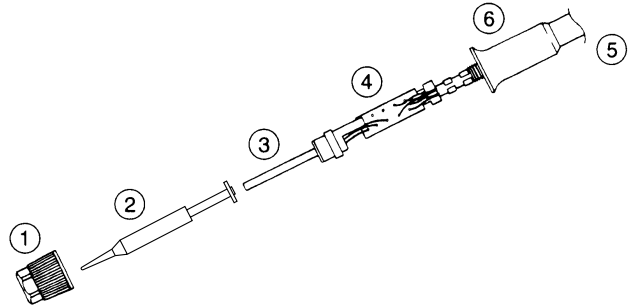

## 907,908

Item No.	Part No.	Part Name	Description	For
1	B1784	Nut		907
	B1794	Nut		908
2	B1786	Tip Enclosure		907
	B1787	Tip Enclosure		908
3		Soldering Tip	See. P. 6	907
		Soldering Tip	See. P. 6	908
4	B2022	Nipple		907
	B2033	Nipple		908
5	B2032	Grounding Spring		907,908
6	A1321	Heating Element	Old part No.900M-H,900L-H	907,908
7	B2028	Terminal Board	w/Cord Stopper	907,908
8	B2023	Handle	w/Handle Cover	907
	B2024	Handle	w/Handle Cover, E.S.D.	907
	B2025	Handle	w/Handle Cover	908
	B2026	Handle	w/Handle Cover, E.S.D.	908
9	B2027	Handle Cover		907,908
10	B2031	Cord Bushing		907,908
11	B2029	Cord Asse'y		907,908
	B2030	Cord Asse'y	E.S.D.	907,908

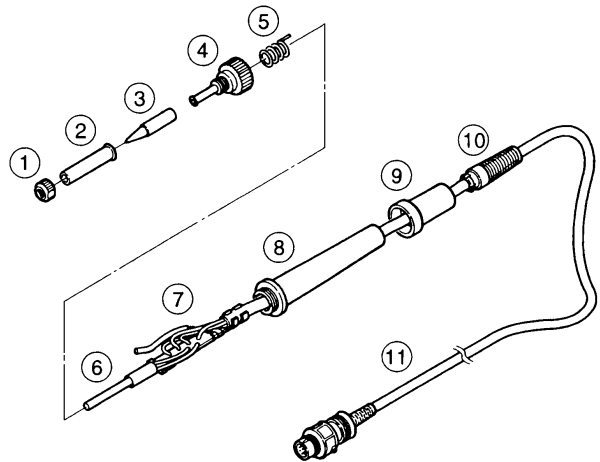

# Wiring Diagram

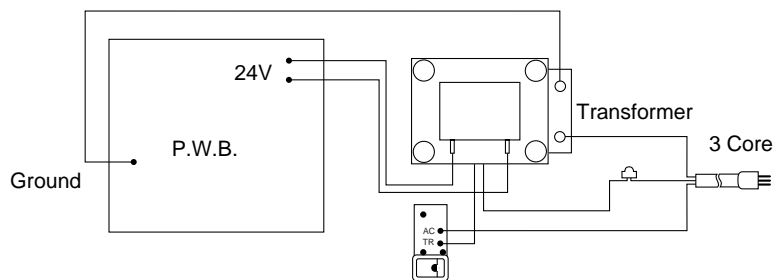

## HAKKO CORPORATION

**HEAD OFFICE**  
4-5, SHIOKUSA 2-CHOME, NANIWA-KU, OSAKA, 556-0024 JAPAN  
TEL: (06) 561-3225 FAX: (06) 561-8466

**OVERSEAS AFFILIATES**  
**U.S.A.:** AMERICAN HAKKO PRODUCTS, INC.  
25072 ANZA DR. SANTA CLARITA, CA 91355, U.S.A.  
TEL: (805) 294-0090 FAX: (805) 294-0096  
Toll Free (800)88-HAKKO

www.hakkousa.com  
**S'PORE:** HAKKO PRODUCTS PTE., LTD.  
1, GENTING LINK #02-04, PERFECT INDUSTRIAL  
BUILDING, SINGAPORE 349518  
TEL: 7482277 FAX: 7440033

**HONG KONG:** HAKKO DEVELOPMENT CO., LTD.  
ROOM 1504 EASTERN HARBOUR CENTRE,  
28 HOI CHAK STREET, QUARRY BAY, HONG KONG.  
TEL: 2811-5588 FAX: 2590-0217

**PHILIPPINES:** HAIKU PHILS TRADING CO., INC.  
NO. 415 WINDSOR TOWER CONDOMINIUM,  
163 LEGASPI ST., LEGASPI VILLAGE MAKATI,  
METRO MANILA, PHILIPPINES  
TEL: 2-817-07-12 FAX: 2-810-76-49

**MALAYSIA:** HAKKO PRODUCTS SDN BHD  
**MALAYSIA HEAD OFFICE:** PETALING JAYA  
LOT 35/1 THE HIGHWAY CENTRE JALAN 51/205 46050  
PETALING JAYA WEST MALAYSIA  
TEL: 03-7941333 FAX: 03-7911232

**PENANG BRANCH:** TEL: 04-644 6669 FAX: 04-644 8628

**JOHORE BAHRU BRANCH:** TEL: 07-236 7766 FAX: 07-237 4655