

HAKKO 155

LEAD CUTTER

Lead Cutter No.155-1

Instruction Manual

Thank you for purchasing the HAKKO 155 Lead Cutter.
 This Manual describes the use and maintenance of the HAKKO 155.
 Please read it before using the unit. After reading the manual,
 keep it in a safe place for future reference.

Packing List

Body.....	1	Hexagon Wrench 2 mm (0.07 in.).....	1
Parts Tray.....	1	Hexagon Wrench 2.5 mm (0.1 in.).....	1
Cramp.....	1	Hexagon Wrench 3 mm (0.12 in.).....	1
Handle.....	1	Hexagon Wrench 4 mm (0.16 in.).....	1

Specifications

No.	155-1
Name	HAKKO 155
External Diameter	110 (W) x 140 (H) x 125 (D) mm 4.3 (W) x 5.5 (H) x 4.9 (D) in.
Weight	Approx. 1.7 kg (3.7 lb.) with Handle and Clamp

①	Maximum Diameter of Lead Wire	φ0.8 mm (0.03 in.)
②	Maximum Processing Part Size	φ12.5 x 25 mm (0.5 x 1.0 in.)
③	Feed Hole Pitch	12.7 mm (0.5 in.)
④	Lead Pitch	5.0 mm (0.2 in.), 2.5 mm (0.1 in.)*
⑤	Minimum Processing Size	1.5 mm (0.06 in.) from taping end 2.0 mm (0.07 in.) from Part end

*When processing a part with lead pitch of 2.5 mm (0.1 in.), be sure to adjust the Cutting Wheel.

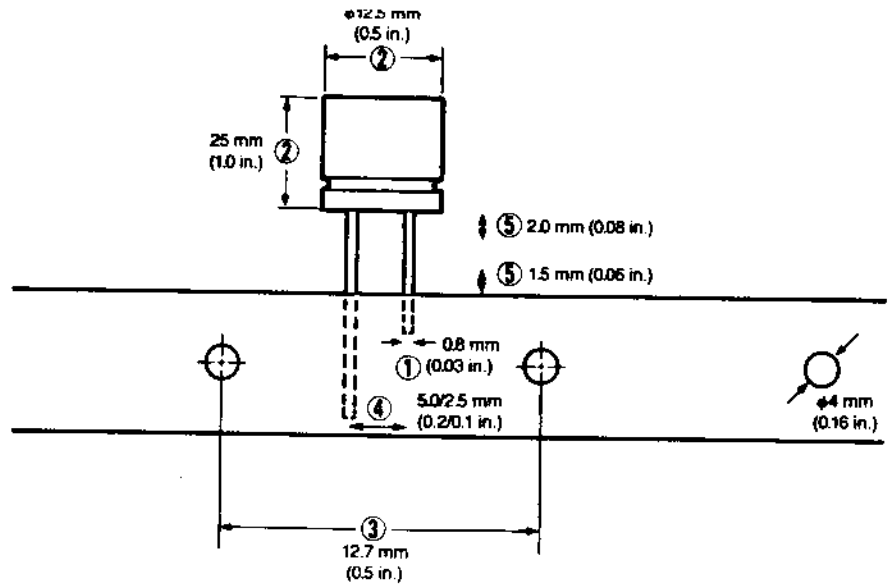

Optional Units

HAKKO 152

MOTOR DRIVE

This is a motor drive for lead formers and lead cutters. It features accurate, high-speed processing at stable torque.

Rotary	40 rpm (50 Hz), 48 rpm (60 Hz)
Size	360 (W) x 150 (H) x 140 (D) mm (14.1 x 6.0 x 5.5 in.)
Weight	Approx. 5.1 kg (11.2 lb.)
Max. Processing Capacity	30,000 pcs./hour.

HAKKO

HAKKO CORPORATION

HEAD OFFICE

4-5, SHIOKUSA 2-CHOME, NANIWA-KU, OSAKA, 556 JAPAN
TEL: (06) 561-3225 FAX: (06) 561-8466
TLX: HAKKOOSA J65274

OVERSEAS AFFILIATES

U.S.A.: AMERICAN HAKKO PRODUCTS, INC.
CORPORATE OFFICE

25072 ANZA DR. SANTA CLARITA, CA 91355, U.S.A.
TEL: (805) 294-0090 FAX: (805) 294-0096
EASTERN OFFICE - NORTH CAROLINA
MID-WEST OFFICE - ILLINOIS

S'PORE: HAKKO PRODUCTS PTE., LTD.

1, GENTING LINK #02-04, PERFECT INDUSTRIAL
BUILDING, SINGAPORE 1334
TEL: 7482277 TLX: RS 37102 HAKKO FAX: 7440033
HONG KONG: HAKKO DEVELOPMENT CO., LTD.
ROOM 1706, ARION COMMERCIAL CENTRE, 2-12,
QUEEN'S ROAD WEST, HONG KONG
TEL: 815-1928 FAX: 541-8217

PHILIPPINES: HAKKO PHILS TRADING CO., INC.

NO. 415 WINDSOR TOWER CONDOMINIUM,
163 LEGASPI ST., LEGASPI VILLAGE MAKATI,
METRO MANILA, PHILIPPINES
TEL: 2-810-76-49 FAX: 2-810-76-49

Operation

① **Fasten the Unit to the work bench.**

- Use the Clamp to attach the Unit to the work bench.

② **Attach the Handle.**

- Fit the Handle in so the end of the Adjustment Screw goes into the groove on the Main Shaft, then tighten the Adjustment Screw with a Hexagon Wrench 3 mm (0.12 in.).

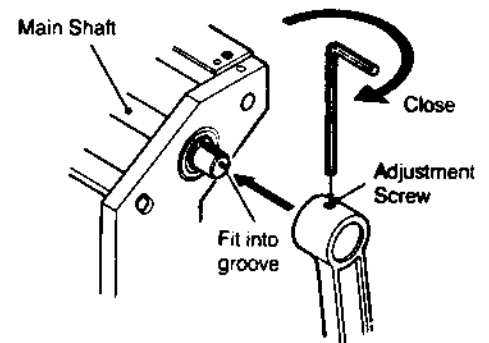

③ **Set the cutting size.**

- Loosen the Set Screw on the Tape Guide and move it in the direction of the Stopper.
- Use a Hexagon Wrench 3 mm (0.12 in.) to loosen the Adjustment Screw on the Transport.
- Match the feed holes on the taped component with the protruding portion on the Transport and adjust the position of the Transport to the desired cutting size. Then tighten the Adjustment Screw.
*The tape on the taped component should be facing up.

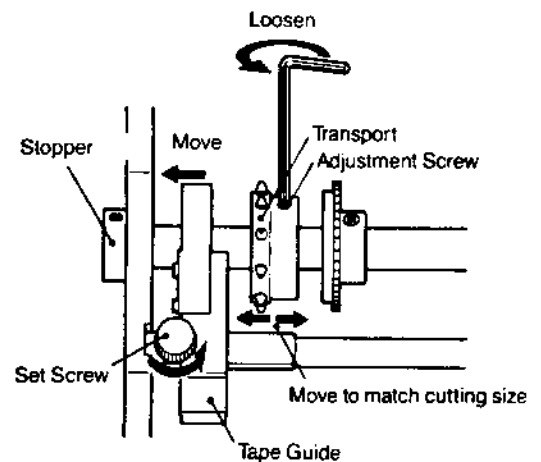

④ **Set the taped component in place.**

- Temporarily remove the taped component.
- Return the Tape Guide to its former position and fasten it in place with the Set Screw.
- Pass the taped component along the Tape Guide and match the feed holes with the protruding portion of the Transport.
- Adjust the Parts Guide so it lightly presses the top of the part, then fasten the Set Screw.

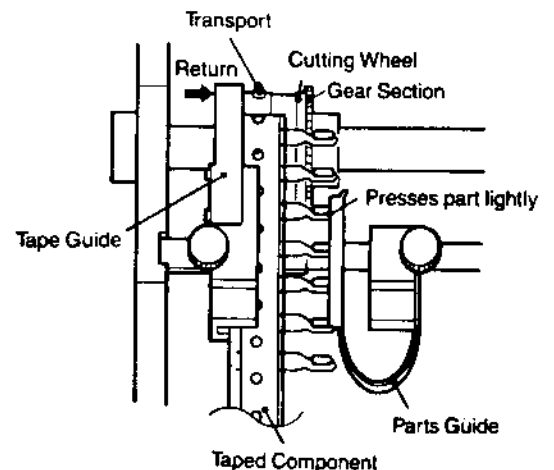

⑤ **Set the Parts Tray in place.**

⑥ **Turn the Handle.**

- Before turning the Handle, check to make sure that the lead of the component meshes perfectly with the gear section of the Cutting Wheel.

Part Names

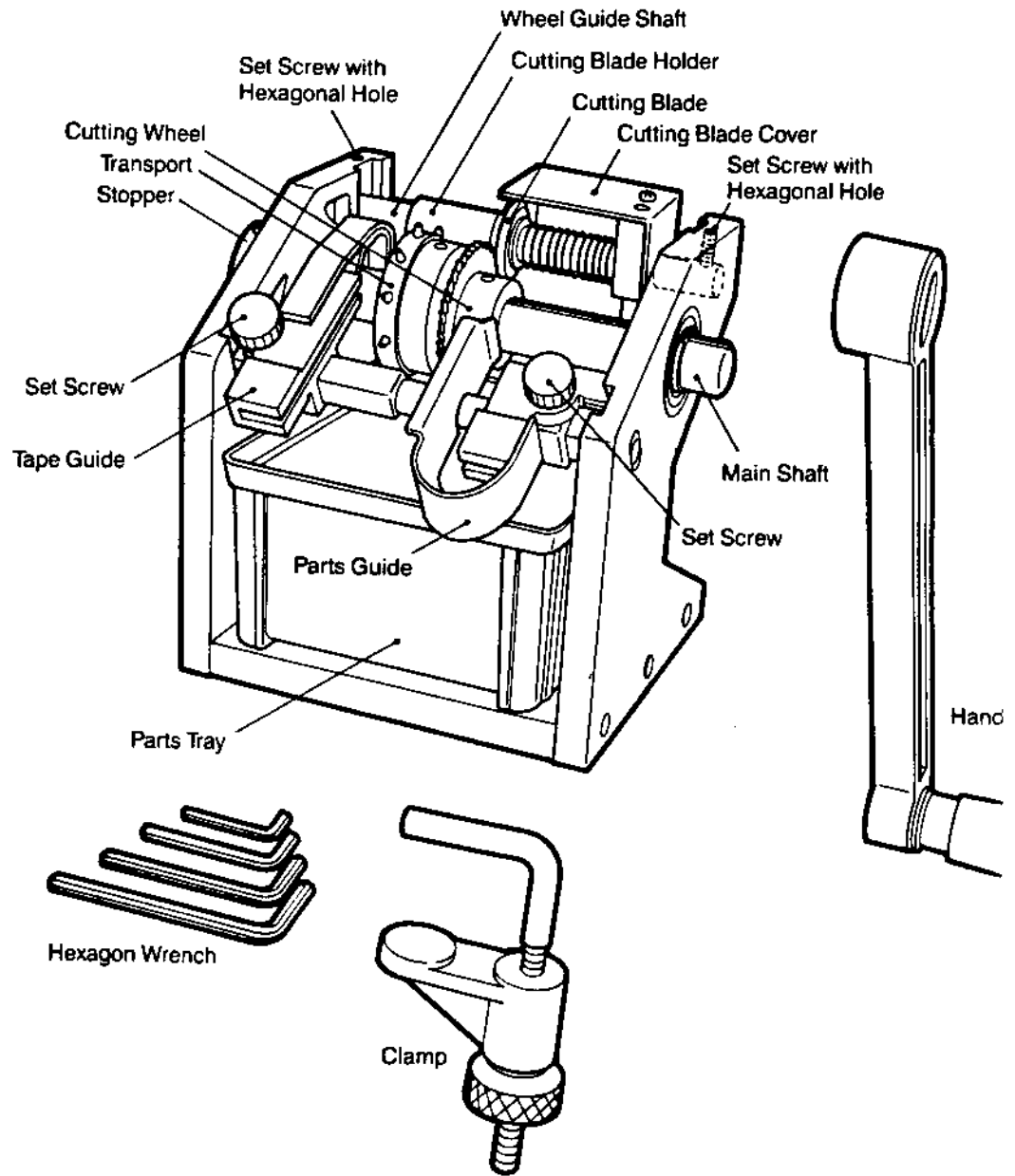

Parts List

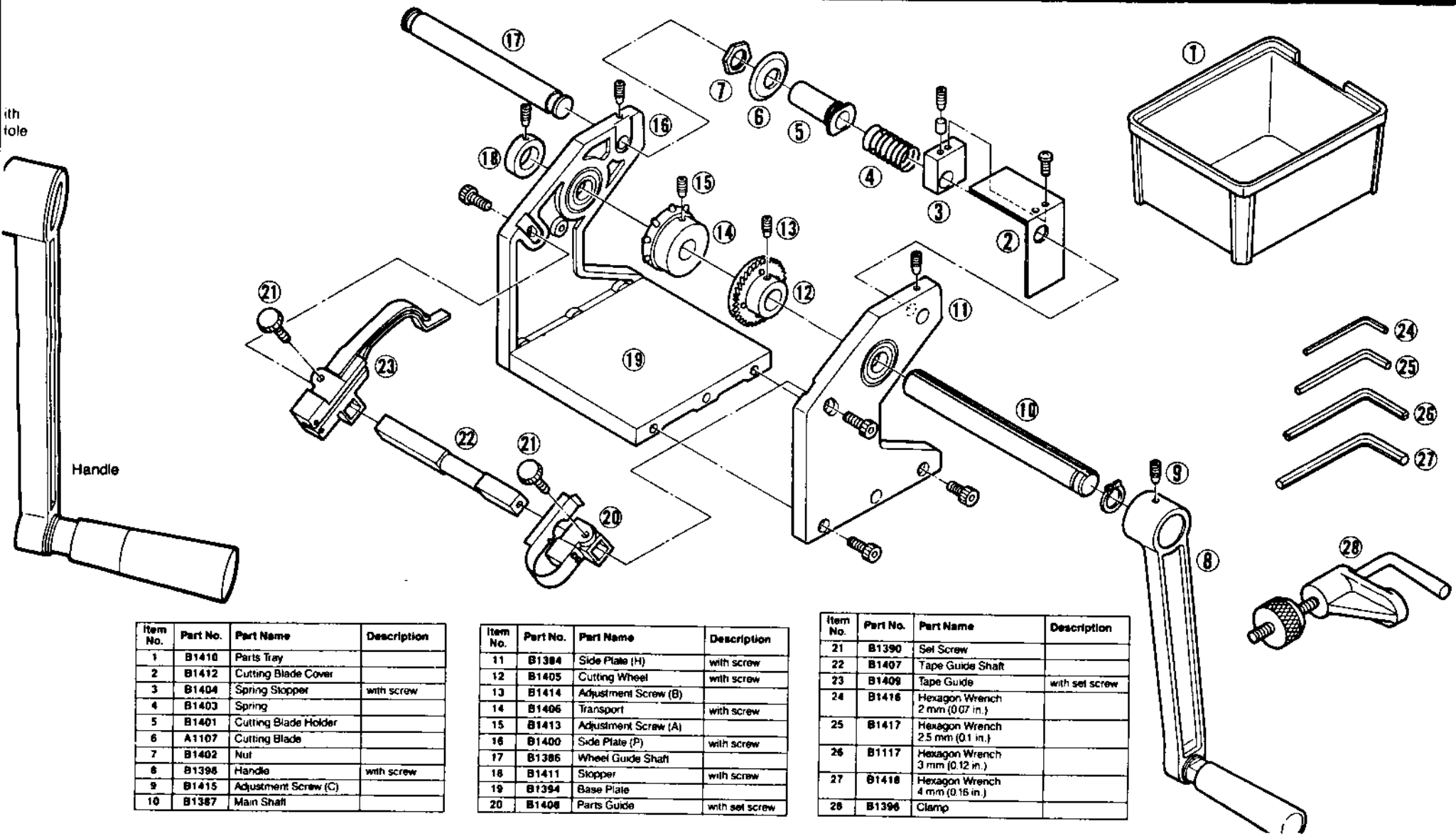

Item No.	Part No.	Part Name	Description
1	B1410	Parts Tray	
2	B1412	Cutting Blade Cover	
3	B1404	Spring Stopper	with screw
4	B1403	Spring	
5	B1401	Cutting Blade Holder	
6	A1107	Cutting Blade	
7	B1402	Nut	
8	B1398	Handle	with screw
9	B1415	Adjustment Screw (C)	
10	B1387	Main Shaft	

Item No.	Part No.	Part Name	Description
11	B1384	Side Plate (H)	with screw
12	B1405	Cutting Wheel	with screw
13	B1414	Adjustment Screw (B)	
14	B1406	Transport	with screw
15	B1413	Adjustment Screw (A)	
16	B1400	Side Plate (P)	with screw
17	B1386	Wheel Guide Shaft	
18	B1411	Stopper	with screw
19	B1394	Base Plate	
20	B1408	Parts Guide	with set screw

Item No.	Part No.	Part Name	Description
21	B1390	Set Screw	
22	B1407	Tape Guide Shaft	
23	B1409	Tape Guide	with set screw
24	B1416	Hexagon Wrench 2 mm (0.07 in.)	
25	B1417	Hexagon Wrench 2.5 mm (0.1 in.)	
26	B1117	Hexagon Wrench 3 mm (0.12 in.)	
27	B1418	Hexagon Wrench 4 mm (0.16 in.)	
28	B1396	Clamp	

When Cutting a Component with a Lead Pitch of 2.5 mm (0.1 in.)

When shipped, the Unit is set for components with a lead pitch of 5.0 mm (0.2 in.). Therefore, when cutting component with a lead pitch of 2.5 mm (0.1 in.), it must first be set as follows:

① Remove the Cutting Wheel.

- Use a Hexagon Wrench 2.5 mm (0.1 in.) to loosen the Set Screw (with the hexagonal hole) on the Cutting Blade Cover.
- Use a Hexagon Wrench 2.5 mm (0.1 in.) to loosen the Set Screw (with the hexagonal hole) on the Stopper, then remove the Stopper.
- Use a Hexagon Wrench 3 mm (0.12 in.) to loosen the Adjustment Screws on the Transport and Cutting Wheel.
- Remove the Main Shaft in the direction of the Handle, then take off the Cutting Wheel.

② Adjust the Cutting Wheel.

- Remove the screws (4) on the Cutting Wheel, then turn the gear section 90° (either clockwise or counter-clockwise) and refasten the screws.

③ Assemble as before.

- Use the same procedure in reverse to assemble.

CAUTION

Fasten the Cutting Blade Cover so it encloses the Cutting Blade. It is dangerous to use the Unit with the Cutting Blade exposed.

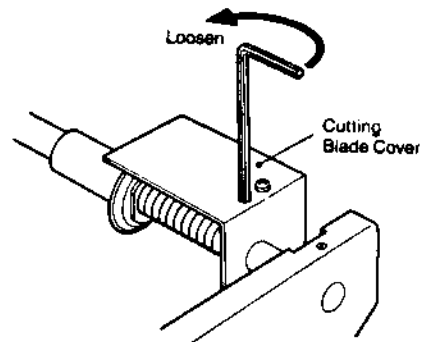

For Cutting Component with a lead pitch of 5.0 mm (0.2 in.)

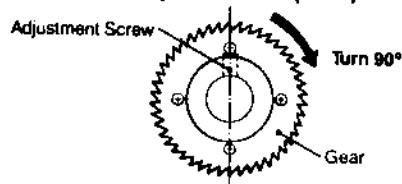

Center of screw should be aligned vertically with gear teeth.



For Cutting Component with a lead pitch of 2.5 mm (0.1 in.)

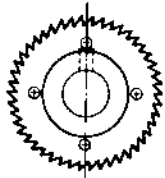

Center of screw should be aligned vertically with valley between gear teeth.

Replacing the Cutting Blade

① Remove the Cutting Blade Holder.

- Use a Hexagon Wrench 2.5 mm (0.1 in.) to loosen the Set Screw (with the hexagonal hole) on the Cutting Blade Cover.
- Use a Hexagon Wrench 2 mm (0.07 in.) to remove the two screws holding on the Wheel Guide Shaft.
- Move the Wheel Guide Shaft in the Handle direction, being careful not to move it enough to dislodge the screw, then remove the Cutting Blade Holder.

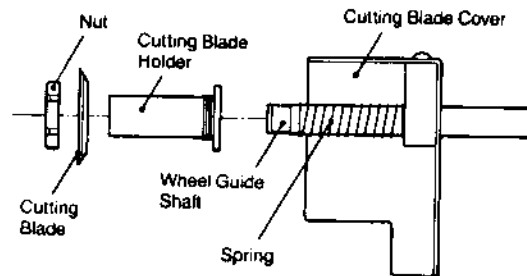

② Replace the Cutting Blade.

- Remove the Nut.
- Remove the Cutting Blade from the Cutting Blade Holder and insert the new blade.

③ Assemble as before.

- Use the same procedure in reverse to assemble.