



205 Westwood Ave  
Long Branch, NJ 07740  
1-877-742-TEST (8378)  
Fax: (732) 222-7088  
salesteam@Tequipment.NET

*Simpson*<sup>®</sup>

## GIMA Multi-Function Electricity Meter OPERATOR'S MANUAL



**SIMPSON ELECTRIC COMPANY**  
520 Simpson Avenue  
Lac du Flambeau, WI 54538  
715-588-3311 FAX: 715-588-7930

Printed in U.S.A. Part No. 06-117285, Edition 2, 03/06  
Visit us on the web at [www.simpsonelectric.com](http://www.simpsonelectric.com)

## About this manual

To the best of our knowledge and at the time written, the information contained in this document is technically correct and the procedures accurate and adequate to operate the instrument in compliance with its original advertised specifications.

## Notes and Safety information

This Operator's Manual contains warning symbols which alert the user to check for hazardous conditions. These appear throughout this manual where applicable, and are defined below. To ensure the safety of operating performance of this instrument, these instructions must be adhered to.



**Warning, refer to accompanying documents.**

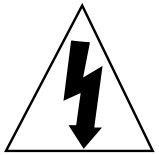

**Caution, risk of electric shock.**



**This instrument is designed to prevent accidental shock to the operator when properly used. However, no engineering design can render safe an instrument which is used carelessly. Therefore, this manual must be read carefully and completely before making any measurements. Failure to follow directions can result in a serious or fatal accident.**

| Digital (Pulse) Outputs |  |
|-------------------------|--|
| Function                | 1 pulse / energy unit (Output #1=N Wh, Output #2=N varh) |
| Scaling                 | Settable 1,10 or 100 counts of associated register       |
| Pulse Period            | 100ms. (2ms Rise, 2ms Fall)                              |
| Type                    | N/O Volt free contact. Optically isolated BiFET          |
| Contacts                | 100mA AC/DC max, 100V AC/DC max                          |
| Isolation               | 2.5kV (50V #1 to #2)                                     |

| General                       |  |
|-------------------------------|--|
| Temperature Operating Storage | -10 deg C to +65 deg C-25 deg C to +70 deg C |
| Environment                   | IP40   |
| Humidity                      | <75% non-condensing                          |

| Mechanical |   |
|------------|---|
| Enclosure  | DIN 96mm x 96mm Mablex ULV94-V-O  |
| Dimensions | 96mm x 96mm x 80mm (72mm behind panel)130mm behind panel with options unit fitted |
| Weight     | Approx. 400g  |
| Terminals  | Rising Cage. 4.0mm2 cable max   |

## Technical Assistance

SIMPSON ELECTRIC COMPANY offers assistance Monday through Friday, 8:00 am to 4:30 pm Central Time. To receive assistance contact Technical Support or Customer Service at (847) 697-2260 or contact us through our web site at [www.simpsonelectric.com](http://www.simpsonelectric.com).

## Warranty and Returns

SIMPSON ELECTRIC COMPANY warrants each instrument and other articles manufactured by it to be free from defects in material and workmanship under normal use and service, it's obligation under this warranty being limited to making good at its factory said instrument or other article of equipment which shall within one (1) year after delivery of such instrument or other article of equipment to the original purchaser be returned intact to it, or to one of its authorized service centers, with transportation charges prepaid, and which its examination shall disclose to its satisfaction to have been thus defective; this warranty being expressly in lieu of all other warranties expressed or implied and of all other obligations or liabilities on its part, and SIMPSON ELECTRIC COMPANY neither assumes nor authorizes any other persons to assume for it any other liability in connection with the sales of its products.

This warranty shall not apply to any instrument or other article of equipment which shall have been repaired or altered outside the SIMPSON ELECTRIC COMPANY factory or authorized service centers, nor which has been subject to misuse, negligence or accident, incorrect wiring by others, or installation or use not in accord with instructions furnished by the manufacturer.

## Starting Serial Numbers 02-24-

# CONTENTS

|   |           |
|---|-----------|
| <b>1. MAINTENANCE</b> .....                                       | <b>1</b>  |
| <b>2. METER OPERATION</b> .....                                   | <b>1</b>  |
| <b>2.1 Measurements</b> .....                                     | <b>1</b>  |
| 2.1.1 Balance Current Measurements .....                          | <b>2</b>  |
| 2.1.2 Rolling Demand (V, I kW, kVA and kvar Demands).....         | <b>2</b>  |
| 2.1.3 Meter Types .....   | <b>2</b>  |
| <b>2.2 Power Up</b> .....   | <b>3</b>  |
| <b>2.3 Display Pages</b> .....                                    | <b>3</b>  |
| <b>2.4 Display Menus</b> .....                                    | <b>8</b>  |
| <b>2.5 Display Scaling</b> .....                                  | <b>9</b>  |
| 2.5.1 Voltage Scaling (Phase, Peak, MD, Pk MD).....               | <b>9</b>  |
| 2.5.2 Line-Line Voltage Scaling (V <sub>L-L</sub> ) .....         | <b>9</b>  |
| 2.5.3 Current Scaling (Phase, Peak, In, MD, Pk MD).....           | <b>9</b>  |
| 2.4.4 Per Phase & System Power Scaling (W, VA, var) .....         | <b>10</b> |
| 2.4.5 Energy Registers (Wh, VAh, varh) .....                      | <b>10</b> |
| 2.4.6 Miscellaneous (Frequency, PF, THD).....                     | <b>10</b> |
| <b>2.6 Energy Register Reset</b> .....                            | <b>11</b> |
| <b>2.7 Peak Voltage Reset</b> .....                               | <b>11</b> |
| <b>2.8 Peak Current Reset</b> .....                               | <b>11</b> |
| <b>2.9 Peak Demand Reset</b> .....                                | <b>11</b> |
| <b>2.10 Isolated Pulse Outputs</b> .....                          | <b>12</b> |
| <b>3. INSTALLATION</b> .....                                      | <b>13</b> |
| <b>3.1 Panel Mounting</b> .....                                   | <b>13</b> |
| <b>3.2 CT Connections</b> .....                                   | <b>14</b> |
| <b>3.3 Voltage Connections</b> .....                              | <b>14</b> |
| <b>3.4 Auxiliary Mains Supply (L &amp; N)</b> .....               | <b>14</b> |
| <b>3.5 Connection Schematics</b> .....                            | <b>15</b> |
| <b>4. PROGRAMMING</b> .....                                       | <b>17</b> |
| <b>4.1 Description</b> .....                                      | <b>17</b> |
| <b>4.2 Entering and Exiting Programming Mode</b> .....            | <b>17</b> |
| <b>4.3 Setting The CT Primary Current</b> .....                   | <b>17</b> |
| <b>4.4 Setting The PT Primary Voltage</b> .....                   | <b>18</b> |
| <b>4.5 Setting Pulse Output 1 Rate</b> .....                      | <b>19</b> |
| <b>4.6 Setting Pulse Output 2 Rate</b> .....                      | <b>20</b> |
| <b>4.7 Setting The Ampere/Voltage Demand Period</b> .....         | <b>21</b> |
| <b>4.8 Setting The kW, kVA, kvar Rolling Average Period</b> ..... | <b>22</b> |
| <b>5. OPTIONS</b> .....   | <b>23</b> |
| <b>5.1 Retro-Fit Modules</b> .....                                | <b>23</b> |
| <b>6. SPECIFICATION</b> .....                                     | <b>24</b> |

| Accuracy          |  |
|-------------------|--|
| Phase Current     | 0.2% Ib (1.0% Rdg. 0.05 Ib £ lph £ 1.2 Ib) ±1 digit. |
| Neutral Current   | 0.6% Ib (2.0% Rdg. 0.05 Ib £ In £ 1.2 Ib) ±1 digit.  |
| Phase Voltage     | 0.2% Vb (1.0% Rdg. 0.2 Vb £ Vph £ 1.2 Vb) ±1 digit.  |
| Line-Line Voltage | 0.3% Vb (1.0% Rdg. 0.2 Vb £ VLL £ 1.2 Vb) ±1 digit.  |
| Phase Watts       | 0.4% FS (1.0% Rdg. 0.05FS £ P £ 1.2FS) ±1 digit.     |
| Phase VA          | 0.6% FS (1.5% Rdg. 0.05FS £ Q £ 1.2FS) ±1 digit.     |
| Phase var         | 0.8% FS (2.0% Rdg. 0.05FS £ S £ 1.2FS) ±1 digit.     |
| Phase PF          | ± 0.2 Degrees  |
| System Watts      | 0.6% FS (1.0% Rdg. 0.05FS £ P £ 1.2FS) ±1 digit.     |
| System VA         | 1.0% FS (1.5% Rdg. 0.05FS £ Q £ 1.2FS) ±1 digit.     |
| System var        | 1.5% FS (2.0% Rdg. 0.05FS £ S £ 1.2FS) ±1 digit.     |
| System PF         | ± 0.2 Degrees  |
| Frequency         | ±0.05Hz. 45Hz £ F £ 65Hz                             |
| Wh Register       | Class 1.0 EN 61036                                   |
| VAh Register      | Class 2.0  |
| varh Registers    | Class 2.0 IEC 1268                                   |
| % THD Amps        | ± 0.5% THD 0.05 Ib £ lph £ 1.2 Ib                    |
| % THD Volts       | ± 0.5% THD 0.2 Vb £ Vph £ 1.2 Vb                     |
| Timebase          | Better than 100ppm                                   |

| Display        |   |
|----------------|---|
| Display Type   | Custom, supertwist, LCD with LED backlight          |
| Data Retention | 10 years minimum                                    |
| Display Format | Stores energy registers, user settings, and peaks   |
| Display Update | 3 Lines 12mm digits + 3.8mm custom legends 1 second |

## 6. SPECIFICATION

| Inputs                                      |   |
|---|---|
| System                                      | 3-Phase 3 or 4 Wire Unbalanced Load   |
| Voltage                                     | Vb. 230 / 400 Volt. 3-Phase 3 or 4 Wire<br>Vb. 63 / 110 Volt optional<br>Vb. 120 / 208 Volt optional        |
| Current                                     | Ib 5 Amp from external current transformers (CTs)<br>Ib 1 Amp optional<br>Fully Isolated (2.5kV each phase) |
| Measurement Range<br>Voltage<br>Current     | 20% to 120%<br>0.5% to 120%   |
| Frequency Range<br>Fundamental<br>Harmonics | 45 to 65Hz<br>Up to 20th harmonic   |
| Input Loading<br>Voltage<br>Current         | Less than 0.1 VA per phase<br>Less than 0.1 VA per phase  |
| Overloads<br>Voltage<br>Current             | x2 for 2 seconds maximum<br>x40 for 0.5 seconds maximum   |

| Auxiliary Supply |  |
|------------------|--|
| Standard         | 230 Volt 50/60Hz ±15%                    |
| Options          | 110 Volt 50/60Hz ±15%. (Others to order) |
| Load             | 5 VA Maximum                             |

## 1. MAINTENANCE

The equipment should be maintained in good working order. Damage to the product should be repaired by the manufacturer. The meter may be cleaned by wiping lightly with a soft cloth. No solvents or cleaning agents should be used. All inputs and supplies must be isolated before cleaning any part of the equipment.

## 2. METER OPERATION

### 2.1 Measurements

The GIMA makes use of a high speed micro-processor and an Analog to Digital converter to monitor input signals from three independent phases. Each phase voltage, current and power (kW) are measured directly and a number of other parameters derived from these in software. The measurement process is continuous with all six signals scanned simultaneously at high speed. Unlike many other sampling systems, which sample one phase after another, this ensures that all input cycles are detected. Distorted input waveforms, with harmonics to the 20th are therefore detected accurately.

Derived parameters are calculated and displayed once a second, scaled by user programmed constants for current and voltage transformers.

Instantaneous power parameters are integrated over long time periods providing a number of energy registers. System frequency is detected by digital processing of the phase 1 voltage signal.

#### 2.1.1 Balance Current Measurements

The rms. value of the instantaneous sum of the three phase currents is available on some GIMA meter types. The total current in a three phase system may be represented as :

$$I_{bal} = I_1 + I_2 + I_3 = I_{LEAK} + I_n$$

$I_{LEAK}$  represents any current leaving the system (e.g. Leakage to earth)  
 $I_n$  represents current in the neutral (4 wire systems only)

**NOTE:** In 3-Phase 3-Wire systems the GIMA must be wired using 3 CTs as shown in Figure 3-3 for balanced current measurements to be made.

## 2.1.2 Rolling Demand (V, I kW, kVA and kvar Demands)

Average values of volts, Amps kW, kVA and kvar (if fitted) are calculated over a user programmable time period (10 - 2500 seconds for V and I, 1 - 60 minutes for kW, kVA and kvar). The displays show the averages for the most recent time period ending at the time the display was last updated. The demand period is continuously updated as time progresses hence the term "Rolling Demand".

### 2.1.2.1 Calculating Rolling Demand

Each user set time period is split into smaller sub-periods (10 for V and I, 15 for kW, kVA and kvar). An average value for measurements taken every second during a sub-period are calculated for each parameter. The most recent 10 (15 for kW, kVA and kvar) sub-period averages are stored in memory as an array. An average of the data in each of these arrays is displayed as MD (rolling demand). On power up (or after a brown-out) the sub-period array values are reset to zero. During the first full MD period the Rolling Demand value will accumulate as the zeroes are replaced with valid sub-period averages.

### 2.1.2.2 Peak Demand (kW, kVA, kvar, V and I Pk)

Peak MD readings are the maximum recorded values of corresponding Rolling Demand values.

These may be used to determine the maximum load requirement of a system. They are often used to determine spare capacity in a supply system, supply plant requirement etc.

On power failure or brown-out Peak Demand values are automatically saved in non-volatile memory within the GIMA. The memory requires no battery and will hold the value for up to 10 years in the absence of mains power.

## 2.1.3 Meter Types

Four Standard GIMA meter types are available to suit a range of applications. The meter type defines a number of display pages which may be selected and the parameters metered. This manual covers all meters independent of type.

## 5. OPTIONS

### 5.1 Retro-Fit Modules

A range of retro-fit options modules are available for the GIMA. These provide additional features to the meter such as Modbus serial communications, analogue outputs, alarms etc. A single options module may be mounted to the rear of the GIMA as shown.

For detailed information on individual options modules refer to the separate Instruction manual.

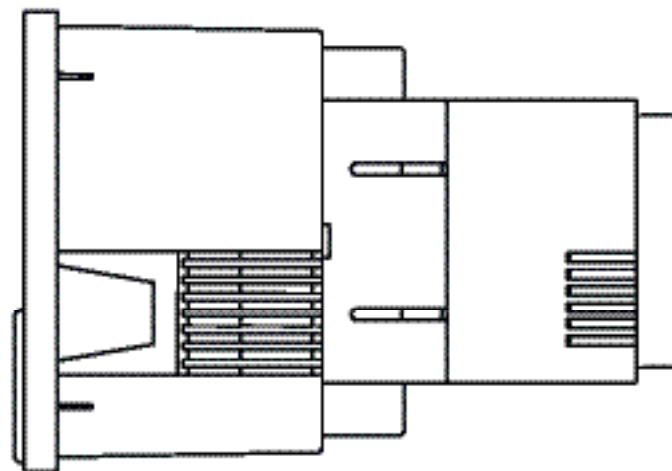
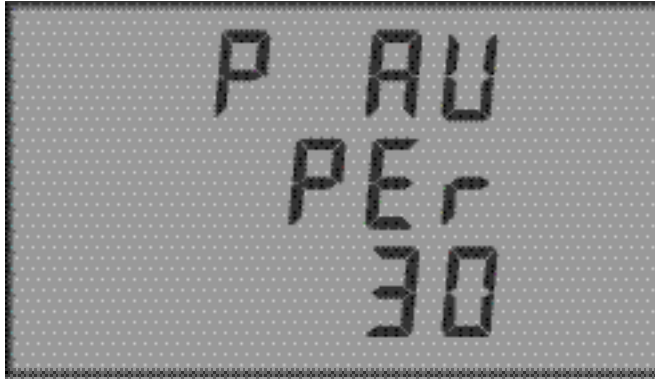

Figure 5-1. Options Module Attached to GIMA

#### 4.8 **Setting The kW, kVA, kvar Rolling Average Period**

The averaging period used in calculation of kW, kVA and kvar Rolling Demands (ref. Section 2.1.2) may be set in the range 1-60 minutes. This period may be selected to match specific standards, or to set a convenient filter for short term fluctuations in input power, as required. During programming, the Average Period is displayed in minutes.



**Figure 4-6. Setting Power Rolling Demand Period**

Press  $\Delta$  to increase the Averaging Period by 1 minute.  
Press  $\nabla$  to decrease the Averaging Period by 1 minute.  
Press  $\leftarrow$  and hold for 2 seconds when done.

#### 2.2 **Power Up**

On power up the GIMA shows the meter type and software issue. The example below shows software issue 1.06 meter type 3

```
CubE  
SOFT  
106-3
```

#### 2.3 **Display Pages**

To select current measurements press the I key repeatedly until the desired page is displayed. The number of pages available is dependant on meter type.

To select voltage measurements press the V key repeatedly until the desired page is displayed. The number of pages available is dependant on meter type.

To select power/energy measurements press the P key repeatedly until the desired page is displayed. The number of pages available is dependant on meter type.

Automatically scrolling pages showing PF, Volts & Amps on each phase are obtained by pressing  $\gg$  once. This is available on all meter types except type 6 (see note).

Display pages available on the full range of GIMA meters are shown below followed by tables showing those available on each standard meter type.



**Phase Currents:** Instantaneous true rms. Current on phases 1, 2 and 3, scaled by the user programmable CT primary.

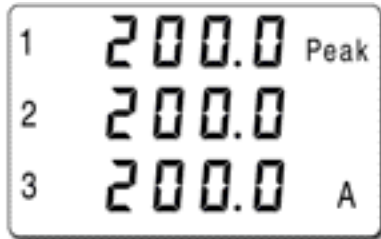

**Peak Hold Currents:** The largest instantaneous reading of phase 1, 2 and 3 currents (above) individually recorded since last reset.



**Balance Current:** The true rms. sum of the three instantaneous current waveforms scaled as phase current above. This is equivalent to neutral current in a three phase 4-wire system.



**Phase Voltages:** Instantaneous true rms. voltages on phases 1, 2 and 3 with respect to neutral. These readings are scaled by user programmable PT primary.

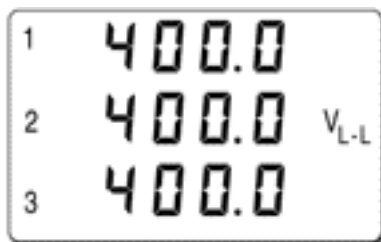

**Line-Line Voltages:** Instantaneous true rms. line to line voltages scaled by user programmable PT primary.  
 1=Line1-Line2  
 2=Line2-Line3  
 3=Line3-Line1

#### 4.7 Setting The Ampere/Voltage Demand Period

The averaging period used in calculation of Ampere and Voltage Rolling Demand (ref. Section 2.1.2) may be set in the range 10-2500 seconds (steps of 10s). This period may be selected to set a convenient filter for short term fluctuations in input power, as required. During programming, the Average Period is displayed in seconds.



Figure 4-5. Setting Ampere/Voltage Demand Period

Press  $\Delta$  to increase the Averaging Period by 10 seconds.  
 Press  $\nabla$  to decrease the Averaging Period by 10 seconds.  
 Press  $\leftarrow$  and hold for 2 seconds when done.



#### 4.6 Setting Pulse Output 2 Rate

Isolated pulse output #2 may be set to provide a single pulse at the end of every 1, 10, or 100 increments of the Total varh register irrespective of display scaling and decimal point. This allows the unit to be configured to suit a wide variety of data logging, building management type applications.

During programming, the Pulse Output #2 Rate is displayed scaled as the total varh register for convenience. A display of "PL2 RATE 100 kVARh" indicates that a single pulse will occur, at output #2, at the end of each 10 kvarh.

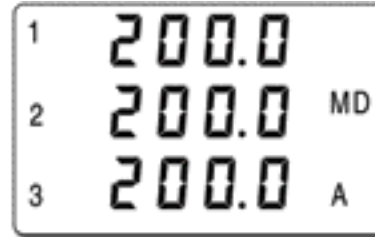

Figure 4-4. Setting the Pulse Output #2 Rate

Press  $\Delta$  to increase the Pulse Output Rate by a factor of 10.  
 Press  $\nabla$  to decrease the Pulse Output Rate by a factor of 10.  
 Press  $\leftarrow$  and hold for 2 seconds when done.



**Peak Hold Voltages:** The largest instantaneous readings of phase voltages (above) individually recorded since last reset.



**Ampere Demand:** MD based on rolling averages of per phase AmpsUser programmable sub-period 10s to 2500s Average based on 10 sub-period values (1s to 250s) Display updated at the end of each sub period

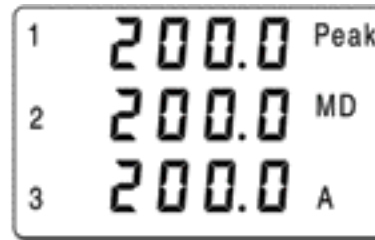

**Peak Ampere Demand:** The largest reading of per phase Ampere Demand values (above) recorded since last reset. Display updated at the end of each sub period

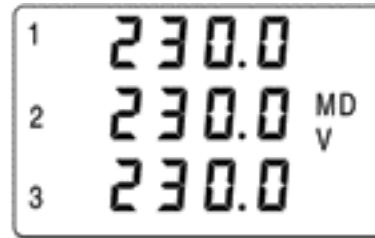

**Voltage Demand:** MD based on rolling averages of per phase VoltsProgrammable sub-period as Ampere Demand Average based on 10 sub-period values (1s to 250s) Display updated at the end of each sub period

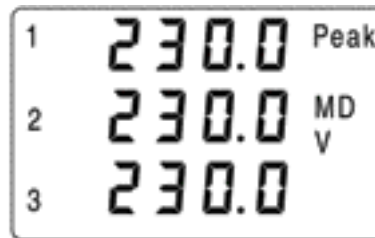

**Peak Voltage Demand:** The largest reading of Voltage Demand values (above) recorded since last reset. Display updated at the end of each sub period

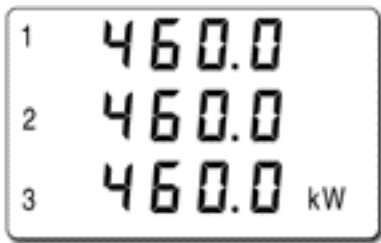

**Phase Watts:** Instantaneous true rms. watts on phases 1,2 & 3,scaled by user programmable CT and PT values.

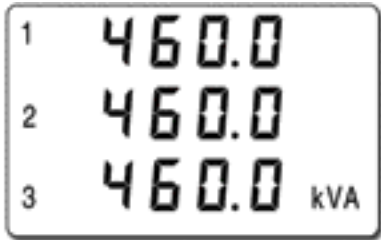

**Phase VA:** Per phase instantaneous VA calculated as:

$$VA1 = V_1 \times I_1$$

$$VA2 = V_2 \times I_2$$

$$VA3 = V_3 \times I_3$$

Where  $V_x$  and  $I_x$  are rms. values.

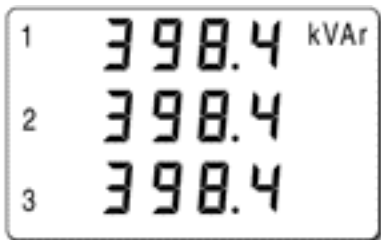

**Phase var:** Per phase instantaneous var calculated as:

$$var_1 = \sqrt{(VA_1^2 - W_1^2)}$$

$$var_2 = \sqrt{(VA_2^2 - W_2^2)}$$

$$var_3 = \sqrt{(VA_3^2 - W_3^2)}$$

Capacitive var shown as negative

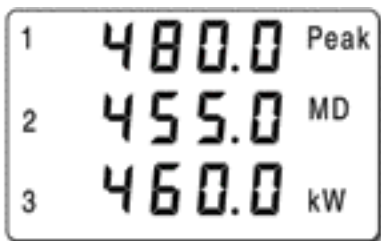

**kW Rolling Max Demand:** MD based on rolling average of system kW :Peak kW MD (largest since last reset)Current Period kW MD Instantaneous kW

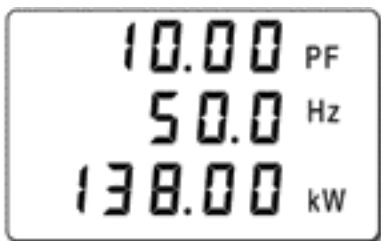

**System PF, Hz, W:** 3-Phase Power Factor ('-' denotes capacitive).Frequency measured on phase 1 voltage.3-Phase instantaneous Watts calculated as  $W1+W2+W3$

#### 4.5 Setting Pulse Output 1 Rate

Isolated pulse output #1 may be set to provide a single pulse at the end of every 1, 10, or 100 increments of the Wh register irrespective of display scaling and decimal point. This allows the unit to be configured to suit a wide variety of data logging, building management type applications.

During programming, the Pulse Output #1 Rate is displayed scaled as the Wh register for convenience. A display of "PL 1 RATE 100 kWh" indicates that a single pulse will occur, at output #1, at the end of each 10 kWh.



Figure 4-3. Setting the Pulse Output #1 Rate

Press  $\Delta$  to increase the Pulse Output Rate by a factor of 10.

Press  $\nabla$  to decrease the Pulse Output Rate by a factor of 10.

Press  $\leftarrow$  and hold for 2 seconds when done.

#### 4.4 Setting The PT Primary Voltage

The next item in the programming menu allows the user to set the PT Primary line-line voltage, in the range 60V to 50,000V, to match the primary of the potential transformers connected to the meter inputs. The secondary of the PTs must match the nominal line-line input voltage specified on the meter label. If no potential transformers are fitted the PT setting must match the nominal line-line input voltage specified on the meter label.

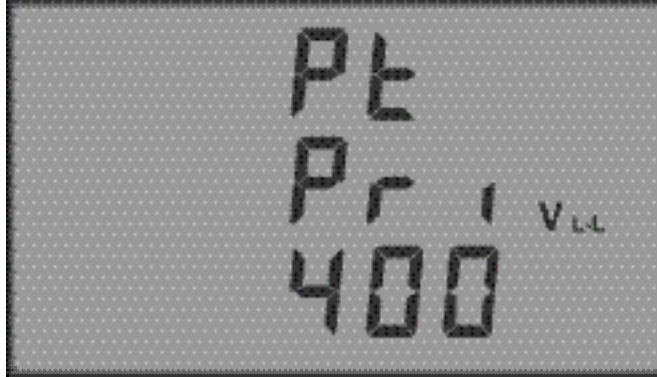
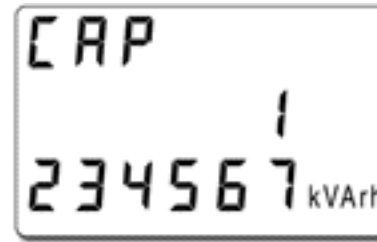
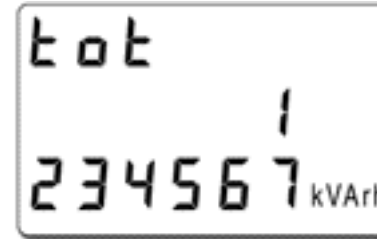

Figure 4-2. Setting the PT Primary Constant

Press  $\Delta$  to increase the PT Primary Constant in steps of 1 Volt.  
 Press  $\nabla$  to decrease the PT Primary Constant in steps of 1 Volt.  
 Press  $\leftarrow$  and hold for 2 seconds when done.



**Capacitive varh Register:** System varh integrated over time is accumulated in this register while the load measured is capacitive (displayed as negative). The most significant digit is displayed on the middle line.



**Total varh Register:** The absolute sum of Inductive + Capacitive varh. The most significant digit is displayed on the middle line.



**Phase 1 PF, Volts & Amps:** Phase 1 PF ('-' denotes capacitive). Phase 1 Voltage scaled as above. Phase 1 Current scaled as above.



**Phase 2 PF, Volts & Amps:** Phase 2 PF ('-' denotes capacitive). Phase 2 Voltage scaled as above. Phase 2 Current scaled as above.



**Phase 3 PF, Volts & Amps:** Phase 3 PF ('-' denotes capacitive). Phase 3 Voltage scaled as above. Phase 3 Current scaled as above.

## 2.4 Display Menus

| G100             |                    |                  |                  |
|------------------|--------------------|------------------|------------------|
| I                | V                  | P                | >>               |
| Phase Currents   | Phase Voltages     | System PF, Hz, W | Phase 1 PF, V, I |
| Ampere Demand    | Line-Line Voltages | Phase Watts      | Phase 2 PF, V, I |
| Pk Ampere Demand | Voltage Demand     |                  | Phase 3 PF, V, I |
|                  | Pk Voltage Demand  |                  |                  |

| G200             |                    |                  |                  |
|------------------|--------------------|------------------|------------------|
| I                | V                  | P                | >>               |
| Phase Currents   | Phase Voltages     | System PF, Hz, W | Phase 1 PF, V, I |
| Ampere Demand    | Line-Line Voltages | Phase Watts      | Phase 2 PF, V, I |
| Pk Ampere Demand | Voltage Demand     | Wh Register      | Phase 3 PF, V, I |
|                  | Pk Voltage Demand  |                  |                  |

| G300             |                    |                          |                  |
|------------------|--------------------|--------------------------|------------------|
| I                | V                  | P                        | >>               |
| Phase Currents   | Phase Voltages     | System PF, Hz, W         | Phase 1 PF, V, I |
| Ampere Demand    | Line-Line Voltages | System PF, Hz, var       | Phase 2 PF, V, I |
| Pk Ampere Demand | Voltage Demand     | Phase Watts              | Phase 3 PF, V, I |
|                  | Pk Voltage Demand  | Phase var                |                  |
|                  |                    | Pk MD, Rolling MD, kW    |                  |
|                  |                    | Wh Register              |                  |
|                  |                    | Total varh Register      |                  |
|                  |                    | Inductive varh Register  |                  |
|                  |                    | Capacitive varh Register |                  |

## 4. PROGRAMMING

### 4.1 Description

The GIMA is designed for use in a wide variety of systems. A range of programmable features allow the unit to be set-up for a specific application. Programming is available using the front panel keypad and display while the unit is operational.

### 4.2 Entering and Exiting Programming Mode

To enter programming, Press I and V together and hold for 5 seconds. When all user programmable settings are complete, Press I and V together and hold for 5 seconds to return to measurement mode.

### 4.3 Setting The CT Primary Current

The first item in the programming menu allows the user to set the CT Primary current, in the range 5A to 20000A, to match the primary of the current transformers connected to the meter inputs. The secondary of the CTs must match the nominal input current specified on the meter label. Once set, the constant acts as a multiplying factor in the internal calculation of relevant measurements.



Figure 4-1. Setting the CT Primary Constant

Press  $\Delta$  to increase the CT Primary Constant in steps of 1 Amp.  
 Press  $\nabla$  to decrease the CT Primary Constant in steps of 1 Amp.  
 Press  $\leftarrow$  and hold for 2 seconds when done.

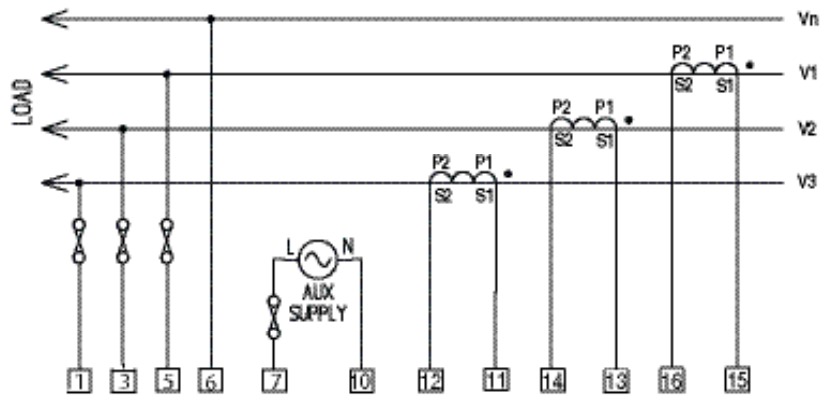

Figure 3.4 3-Phase 4-Wire

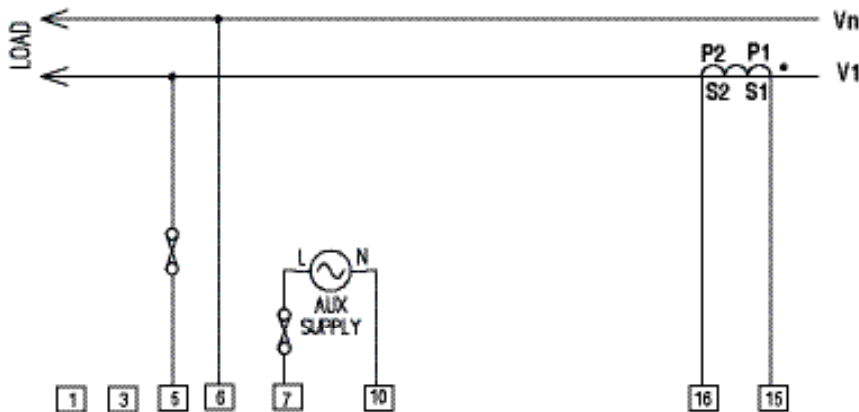

Figure 3-5. Single Phase

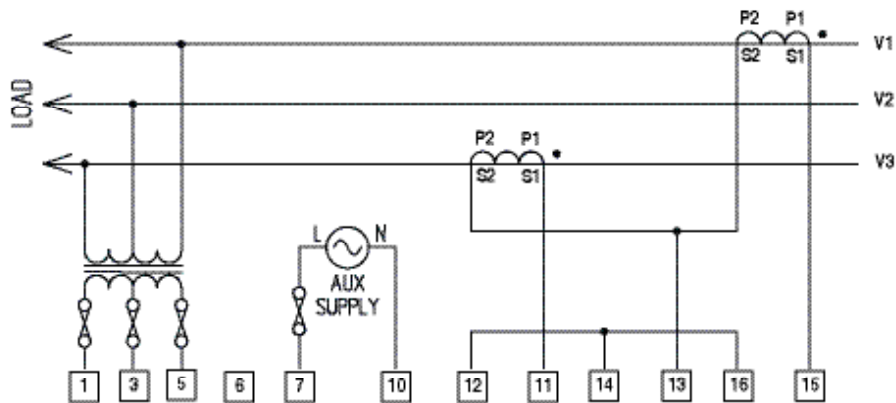

Figure 3-6. 3-Phase 3-Wire using Potential Transformers

## 2.5 Display Scaling

The GIMA scales its displays automatically to provide the optimum resolution dependant on user settings (CT and PT Primary). This provides direct reading of parameters with decimal points and legends automatically selected (e.g. kW or MW etc).

### 2.5.1 Voltage Scaling (Phase, Peak, MD, Pk MD)

| PT Setting              | Example Display |
|-------------------------|-----------------|
| 60VL-L - 140VL-L        | 20.00 V         |
| 141VL-L - 1,400VL-L     | 200.0 V         |
| 1,401VL-L - 14,000VL-L  | 2.000 kV        |
| 14,001VL-L - 50,000VL-L | 20.00 kV        |

### 2.5.2 Line-Line Voltage Scaling ( $V_{L-L}$ )

| PT Setting             | Example Display |
|------------------------|-----------------|
| 60VL-L - 80VL-L        | 50.00 VL-L      |
| 81VL-L - 800V          | 500.0 VL-L      |
| 801VL-L - 8,000VL-L    | 5.000 kVL-L     |
| 8,001VL-L - 50,000VL-L | 50.00 kVL-L     |

### 2.5.3 Current Scaling (Phase, Peak, In, MD, Pk MD)

| CT Setting       | Example Display |
|------------------|-----------------|
| 5A - 8A          | 5.000 A         |
| 9A - 80A         | 50.00 A         |
| 81A - 800A       | 500.0 A         |
| 801A - 8,000A    | 5.000 kA        |
| 8,001A - 20,000A | 20.00 kA        |

### 2.4.4 Per Phase & System Power Scaling (W, VA, var)

| PT Setting x CT Setting         | Example Display |
|---------------------------------|-----------------|
| 300VA - 1,400VA                 | 200.0 W         |
| 1,401VA - 14,000VA              | 2.000 kW        |
| 14,001VA - 140,000VA            | 20.00 kW        |
| 140,001VA - 1,400,000VA         | 200.0 kW        |
| 1,400,001VA - 14,000,000VA      | 2000 kW         |
| 14,000,001VA - 140,000,000VA    | 20.00 MW        |
| 140,000,001VA - 1,000,000,000VA | 200.0 MW        |

### 2.4.5 Energy Registers (Wh, VAh, varh)

| PT Setting x CT Setting         | Example Display |
|---------------------------------|-----------------|
| 300VA - 1,400VA                 | 9999.999 kWh    |
| 1,401VA - 14,000VA              | 99999.99 kWh    |
| 14,001VA - 140,000VA            | 999999.9 kWh    |
| 140,001VA - 1,400,000VA         | 9999999 kWh     |
| 1,400,001VA - 14,000,000VA      | 99999.99 MWh    |
| 14,000,001VA - 140,000,000VA    | 999999.9 MWh    |
| 140,000,001VA - 1,000,000,000VA | 9999999 MWh     |

### 2.4.6 Miscellaneous (Frequency, PF, THD)

| All Settings         | Example Display |
|----------------------|-----------------|
| System and Phase PF  | 1.000 PF        |
| Amps and Volts % THD | hd 99.9         |
| Frequency            | 50.0 hz         |

### 3.5 Connection Schematics

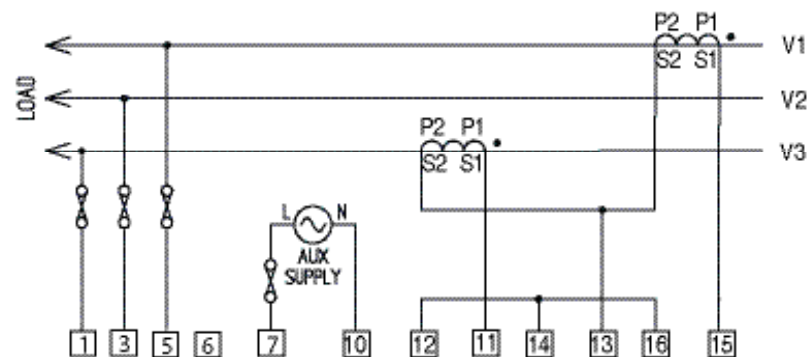

Figure 3-2 3-Phase 3-Wire 2CTs (Not suitable for neutral current measurements)

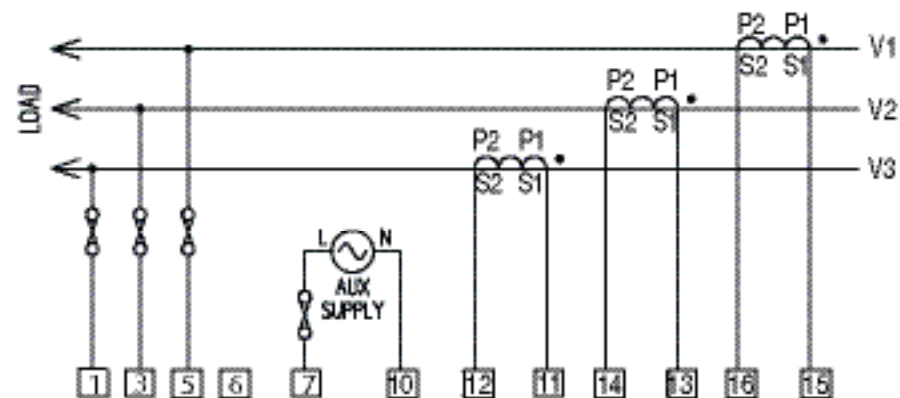

Figure 3-3 3-Phase 3-Wire 3CTs

### **3.2 CT Connections**

The GIMA is designed for use with external current transformers (CTs). Recommended types should conform to Class 1 per IEC 60044-1. The secondary of the CT should be specified to suit the input rating defined on the meter label. Cables used for the current circuit should have a maximum conductor size of 4.0mm<sup>2</sup> and should be kept as short as possible to reduce cable losses loading the CT secondary. CT Inputs to the meter are isolated from each other and all other parts of the circuit. This allows use on a wide variety of systems including those requiring common and/or earthed CT secondaries.

#### **WARNING :**

NEVER leave the secondary of a current transformer open circuit while a primary current flows. In this condition dangerous voltages may be produced at the secondary terminals.

### **3.3 Voltage Connections**

Cables used for the voltage measurement circuit should be insulated to a minimum of 600V AC and have a minimum current rating of 250mA. The maximum conductor size is 4.0mm<sup>2</sup>. External protection fuses are recommended for the voltage measurement inputs. These should be rated at 160mA maximum, Type F, and should be able to withstand voltages greater than the maximum input to the meter.

### **3.4 Auxiliary Mains Supply (L & N)**

The GIMA uses an isolated auxiliary mains supply separate from the voltage measurement inputs. This may be connected separately or in parallel with the measurement inputs provided the ratings detailed on the instrument label are not exceeded.

Separate connection of the auxiliary mains is required, for example, when :

- ◆ A suitable supply voltage is not available locally.
- ◆ Measurement voltages are expected to vary over a wide range
- ◆ A backup supply is required to maintain meter display

The auxiliary mains supply is internally fused at 250V, 100mA type T. External fusing is required if the auxiliary supply voltage exceeds 250V. The meter ratings are detailed on the instrument label.

#### **WARNING :**

**CHECK the instrument LABELS for correct input ratings.  
Incorrectly rated inputs may permanently damage the device**

### **2.5 Energy Register Reset**

All accumulating energy registers may be simultaneously reset to zero using the front panel keys. Once reset, energy readings are lost forever so great care must be taken when using this feature. To reset all energy registers

- ◆ Select any energy display page as described above
- ◆ Press P and >> keys together and Hold for 5 seconds.

### **2.6 Peak Voltage Reset**

The peak voltage readings may be simultaneously reset to zero using the front panel keys. Once reset the old values will be immediately replaced by the latest instantaneous readings and subsequent peaks as they occur. To reset Peak Voltages

- ◆ Select the Peak Voltage display page as described above
- ◆ Press P and >> keys together and Hold for 5 seconds.

### **2.7 Peak Current Reset**

The peak current readings may be simultaneously reset to zero using the front panel keys. Once reset the old values will be immediately replaced by the latest instantaneous readings and subsequent peaks as they occur. To reset Peak Amps

- ◆ Select the Peak Current display page as described above
- ◆ Press P and >> keys together and Hold for 5 seconds.

### **2.8 Peak Demand Reset**

Peak rolling demand readings (Volts, Amps kW, kVA and kvar) may be reset to zero using the front panel keys. At the end of the next sub period the peak will be set to the latest rolling average value. To reset the Peak MD

- ◆ Select the Peak Amps, Volts, kW, kVA or kvar Demand display page as required
- ◆ Press P and >> keys together and Hold for 5 seconds.



## 2.9 Isolated Pulse Outputs

GIMA meters which display kWh and/or kvarh incorporate isolated pulse output(s). These outputs provide a simple interface to external systems such as building management centres etc.

Each output takes the form of a normally open, volt free contact pair which provides a low resistance, for 100mS, at the end of a pre-set number of increments of the associated energy register ('pulse rate'). The pulse rate of each output may be programmed by the user to match the requirements of the external system. For further details on programming the GIMA refer to Section 4.

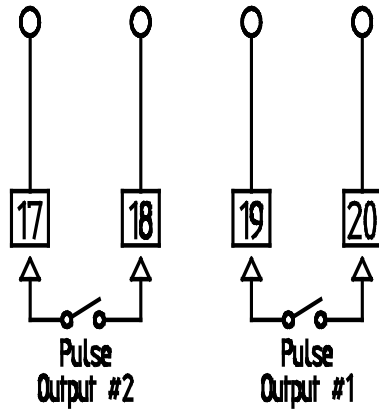

## 3. INSTALLATION

### 3.1 Panel Mounting

Panels should be of thickness 1mm to 4mm with a square cut-out of 92mm (+0.8 - 0.0). A minimum depth of 72mm should be allowed behind the panel for the meter. Remove the panel mounting clips and insert the meter into the cut-out from the front of the panel. Push the meter home. Ensure the screws in each panel mount clip are fully retracted and insert the clips as shown in the diagram below. Tighten the screws to secure the meter firmly in the panel.

**DO NOT OVERTIGHTEN.**

