

# REFRIGERANT RECOVERY/EVACUATION SYSTEM from **PROMAX™**



**COOLTECH**  
INSIDE

US patents: 4,523,897; 5,209,653,  
other US and foreign patents pending.

# ProVax™

## USER'S OPERATING MANUAL

ADVANCED TEST PRODUCTS, INC. • Miramar, FL  
Telephone: (954) 499-5400 • Fax: (954) 499-5454 • Toll Free: (800) 327-5060  
[www.ProVaxAC.com](http://www.ProVaxAC.com)

# TABLE OF CONTENTS

INTRODUCTION	2
IMPORTANT SAFETY INFORMATION and OPERATING GUIDELINES	3-4
CARE AND MAINTENANCE OF YOUR ProVax™	5
ADDITIONAL RECOVERY TANK INFORMATION	6
PURGING NON-CONDENSABLE GASES	7
HELPFUL HINTS FOR REFRIGERANT RECOVERY & EVACUATION	8-9
OPERATING YOUR ProVax™	10-11
SELF PURGING YOUR ProVax™	12
PULLING A VACUUM	12
DIAGRAM FOR REFRIGERANT RECOVERY & EVACUATION	12-13
DIAGRAM FOR "PUSH/PULL" METHOD	13
SET-UP DIAGRAM FOR TANK PRE OR SUB COOLING PROCEDURE	13
OPTIONAL RECOVERY / TANK PRE OR SUB COOLING FOR FIXED HOSE SET-UP	14
VACUUM PUMP MAINTENANCE / OIL CHANGE	15
ProVax PARTS DIAGRAM/PARTS AND ACCESSORIES LIST	16-17
ProVax WIRING DIAGRAM	18
INSTALLATION OF OPTIONAL 80% TANK CAPACITY SENSING KIT	19
TROUBLESHOOTING YOUR PROVAX™	20-21
SPECIFICATIONS	22
WARRANTY INFORMATION	23
ENVIROMENTAL PROTECTION AGENCY (EPA) INSTRUCTIONS	24
EPA REGIONAL OFFICES	25

# INTRODUCTION

Congratulations on your purchase of the ProVax™ refrigeration recovery/evacuation system. Using an innovative new design (patents pending), Promax™ has created a unique recovery system. The ProVax™ combines both a recovery unit and a vacuum pump into one unit, conveniently eliminating the need to carry both to the job site.

A Robinair Cooltech® 6 CFM vacuum pump, using a two-stage, offset rotary vane design, provides a powerful high vacuum capability and assures moisture removal, while its high pumping capacity reduces evacuation time. US patents: 4,523,897; 5,209,653, other US and foreign patents pending.

The ProVax™ provides everything you need to recover and evacuate a system, all in one package.



## ⚠ IMPORTANT SAFETY & OPERATING GUIDELINE INFORMATION ⚠

### PERSONAL SAFETY

⚠ SAFETY COMES FIRST! Read all safety, operating guidelines and instructions before operating your ProVax™.

**CAUTION: ONLY A QUALIFIED TECHNICIAN SHOULD OPERATE THIS RECOVERY UNIT.** The operator must be familiar with air conditioning and refrigeration systems, refrigerants and the dangers of pressurized components.

Always think before acting, familiarity breeds carelessness and carelessness can be harmful to your health, or worse, result in death.

⚠ **WARNING:** Always wear safety goggles and protective gloves when working with refrigerants. Contact with refrigerant may cause injury. Disconnect hoses with extreme caution! All hoses may contain liquid refrigerant under pressure.

Read all safety information regarding the safe handling of refrigerant and refrigerant oil, including the Material Safety Data Sheet. MSDS sheets can be obtained from your refrigerant supplier.

Be sure that any room where you are working is thoroughly ventilated, especially if a leak is suspected. Refrigerant vapor is hazardous to your health and can cause death.

⚠ Avoid breathing A/C refrigerant and lubrication vapor or mist. Exposure may irritate eyes, nose and throat. If accidental system discharge occurs, ventilate work area before resuming service.

To reduce the risk of injury, care should be taken when moving this equipment.

Promax strongly recommends the use of the optional 80% Capacity Shutoff Kit (p/n KT-5002).

When installed and used with a recovery tank that has an internal float switch, the ProVax will shut down automatically when the tank is 80% full. Your ProVax is pre-wired from the factory for this kit.

⚠ A scale must be used to avoid overfilling the storage tank. **DO NOT OVERFILL.** Tank is full at 80% volume. Tank may explode if filled more than 80% due to liquid expansion. **Table 1** is a representative sample for R-22 refrigerant:

TANK SIZE	MAX NET WEIGHT
30 lb. Tank	24 lbs.
50 lb. Tank	40 lbs.

TABLE 1: Representative Sample, R-22

Note: Promax strongly recommends the use of the ADS-100 Refrigerant Scale for monitoring tank capacity.

Your ProVax has two Internal Pressure Shut Off switches, a standard 400psi and a 550psi (when the High Pressure [R410A] switch is engaged). The shut off switches will automatically reset after the pressure drops below 200 psi.

⚠ **WARNING:** The Internal Pressure Shut Off Switches **do not** prevent tank overflow. If your system shuts off on high pressure and is connected to your tank, you may have overfilled your tank and created a very dangerous situation! Take immediate measures to relieve any high pressure and/or tank overflow.

When recovering large amounts of liquid, use the "Push/Pull method (see diagram on page 13).

⚠ **CAUTION:** When using the "Push/Pull" method, once the "Push/Pull" siphon is started, it can continue and overflow the storage tank even if the tank is equipped with a "shut off" float sensor. The siphon can continue even after the machine is turned off. You must manually close the valves on the tank and the unit to prevent overflowing of the recovery tank.

Always operate the unit on a flat level surface.

If the tank pressure exceeds 300 psi, use the tank cooling procedure to reduce the tank pressure. (See Pages 13 & 14)

## **IMPORTANT SAFETY & OPERATING GUIDLINE INFORMATION**

**CONT-**

### **ELECTRICAL SAFETY**

When using an extension cord it should be a 3-wire, 14 AWG minimum and no longer than 25 feet.

 **WARNING!** Whenever you perform any type of maintenance work on your ProVax, insure that it is disconnected from the power supply before you begin.

### **FIRE SAFETY**

 **WARNING: TO REDUCE THE RISK OF FIRE:**  
Never operate unit in an explosive environment!  
Do not use this equipment in the vicinity of spilled or open containers of gasoline or any other flammable liquid.

Use this equipment in locations with mechanical ventilation that provides at least four air changes per hour or locate the equipment at least 18 inches above the floor.

Never use oxygen when testing for leaks.  
Any oil in contact with oxygen under pressure will form an explosive mixture.

### **REFRIGERANT SAFETY**

ProVax is approved for use with the following category III, IV and V refrigerants (Per ARI 740):  
R-12, R-22, R-134A, R-401A, R-401B, R-401C,  
R-402A, R-402-B, R-404A, R-406A, R-407A,  
R-407-B, R-407C, R-407D, R-408A, R-409A,  
R-410A, R-411A, R-411B, R-412A, R-500, R-502,  
R-507 and R-509

Always open service and cylinder valves slowly. This allows rapid control of the flow of gases if there is any danger. Once it is determined that there is no danger, the valves can be opened fully.

Always isolate large amounts of refrigerant and close off valves after use, so if a leak should develop anywhere in the system, the refrigerant will not escape.

Keep all connections to the refrigeration system thoroughly dry and clean. If moisture enters the refrigeration system, it is likely to cause considerable damage.

 **WARNING!**  
Pressurized tank contains liquid refrigerant. Never overfill storage tanks. Overfilling of the tank may cause a violent explosion and possible injury or death. Do not exceed the working pressure of Recovery Tank cylinder.

## CARE AND MAINTENANCE OF YOUR ProVax™

Use of a filter/dryer at the inlet is mandatory. A filter/dryer must always be used between the recovery machine and the inlet hose. We recommend that a clean filter be used for every service job. Failure to use a filter will invalidate your warranty.

The use of a filter will greatly reduce the risk of damage to your ProVax, by preventing foreign material from entering the unit.

Each filter should be labeled and used exclusively for one type of refrigerant only.

Special care should be taken when recovering from a "burned-out" system. Use two high acid capacity filters, in series. (Alco type EK-162-F or Sporlan type C-162-F are recommended) When you have finished recovering from the system, flush your ProVax with a small amount of clean refrigerant and refrigerant oil to purge off any foreign substances left in the unit.

Do not expose Vacuum Pump to pressure. It is protected by a pressure cut-off switch set at 25 psi (+/- 5).

Maximum vacuum level 13 in. Hg while in Recovery mode. The compressor is protected by a low pressure cut-out switch set at 13 in. Hg (+/- 3). Use Vacuum mode to fully evacuate system.

Always empty refrigerant from the ProVax into a storage tank; see Self-Purge procedure on Page 12. Liquid refrigerant left in the ProVax's condenser may expand, causing damage to components.

If the unit is to be stored or not used for any length of time, we recommend that it be completely evacuated of any residual refrigerant and purged with dry nitrogen.



## ADDITIONAL RECOVERY TANK INFORMATION

**⚠ WARNING:** Also read the information pertaining to recovery tanks, previously listed under Safety Information and Operating Guidelines.

**⚠ CAUTION:** NEVER use a standard disposable 30 lb. (the type of container in which virgin refrigerant is sold) to recover refrigerant. Use ONLY authorized refillable refrigerant tanks. Federal regulations require refrigerant to be transported only in containers meeting DOT specs. 4BA or 4BW.

**⚠ WARNING:** DO NOT: Exceed the working pressure of each cylinder. Recovery cylinders are designed for different pressures. Your ProVax is not supplied with a recovery tank, it requires the use of tanks with a minimum of 350 psi working pressure and Promax strongly recommends the use of 400 psi tanks.

NOTE: The use of a 400 psi tank is mandatory when recovering R-410A. See Promax Recovery Tanks under Parts and Accessories section on Page 17.

Tanks and filters should be designated for one refrigerant only. Before using a tank previously used for another refrigerant, completely empty the tank, evacuate it and purge the tank using dry nitrogen, and then re-evacuate it.











Always store refrigerant containers in a cool dry place.

Do not mix refrigerants in a system, a tank or anywhere else. Each type of refrigerant must have its own tank, filter, etc.

Storage cylinders sometimes have valves that are not properly seated when manufactured. Keeping caps on these valves will guard against refrigerant leakage.

Safety codes recommend that closed tanks not be filled over 80% of volume with liquid. The remaining 20% is called head pressure room.

**⚠ WARNING! NEVER TRANSPORT AN OVERFILLED CYLINDER**  
Refrigerant expands when it gets warm and may cause a tank to explode if overfilled.

CYLINDER TEMPERATURE	60°F	70°F	100°F	130°F	150°F
<b>STARTING WITH CYLINDER 80% BY VOLUME</b>					
<b>SPACE OCCUPIED BY LIQUID</b>	80%	81%	83%	90%	94%
<b>STARTING WITH CYLINDER 90% BY VOLUME</b>					
<b>SPACE OCCUPIED BY LIQUID</b>	90%	92%	96%	100%	

## PURGING NON-CONDENSABLE GASES FROM REFRIGERANT TANK

1. Allow the tank to sit undisturbed for 24 hours. This allows the air to rise to the top.
2. Connect a manifold to the tank and read the amount of pressure in the tank by looking at the output pressure gauge.
3. Determine the ambient temperature in the room.
4. Refer to a Refrigerant pressure/temperature chart. Find the temperature on the chart and look across to the corresponding pressure for the type of refrigerant in the tank. Determine how that relates to the reading on the gauge.
5. If the pressure reading is higher than the pressure shown on the chart, very slowly (so as not to cause turbulence inside the tank) crack open the vapor port valve. Watch the pressure on the gauge decrease. To prevent venting, add 4-5 psi to the pressure shown on the chart. When the gauge corresponds to that pressure, close the vapor port valve.
6. Allow the tank to sit for 10 minutes and check the pressure again.
7. Repeat the process again if necessary.



# HELPFUL HINTS FOR REFRIGERANT RECOVERY

Refrigerant recovery has come a long way in a few short years. On the surface it's simply the process of taking refrigerant out of a system and putting it into a tank. However, this simple process can quickly become problematic if a few items are overlooked. The following are some tips and pointers we've accumulated over the last few years that can save you time and make the process go smoother.

First you need to identify the refrigerant type and quantity in the system you are servicing. If you determine it's a burnout, you need a special tank (a tank that's identified as containing burnout or other unidentified gases), and you need to use extra filtration prior to recovery. (See "special care" note on page 5).

If, on the other hand, you know the gas in the system is relatively clean or new, then a new tank should be used. If you're planning on putting the refrigerant back into the same system after you have finished the service or if the refrigerant is going to be reclaimed, then use a tank that has the same refrigerant in it. A word of caution about the Environmental Protection Agency (EPA): If you use a variety of refrigerant gasses in your service work - as evidenced by your refrigerant purchases - and you only own one tank, you are asking for trouble. You would be well advised to own at least one tank for every refrigerant type serviced, plus an extra for burnouts and other unknowns.

## PLANNING AHEAD

Knowing the quantity of refrigerant is important for planning storage requirements, as well as planning for the actual recovery. For instance, any system with more than 5lbs. of refrigerant is likely to have areas where the liquid can get trapped.

The key to a quick recovery procedure is to get the liquid out first, and then get the remaining vapor out. However most systems are not "*recovery friendly*." That is they don't have access ports at their lowest points. If some units you're servicing are on maintenance contracts, you would save significant time by installing access ports at all of the lowest points in the system, where liquid is likely to accumulate.

Since most systems don't have these ports you need to be prepared to boil off the trapped liquid with a heat gun, when ever it's found. An indicator of trapped liquid in a system is frost or condensation forming on the plumbing or components where the liquid is trapped. The trapped liquid may be in an area that is not visible. In all cases trapped liquid in a system during recovery causes the recovery process to slow down, regardless of the size or type of machine (*see diagram*).

If you are unable to locate the trapped liquid, but you know it's there, because the recovery job is taking "*forever*". Turn on the system compressor (if it's operable) for a few seconds, this will get the refrigerant moving to another part of the system and in the process pick up enough heat to boil off.

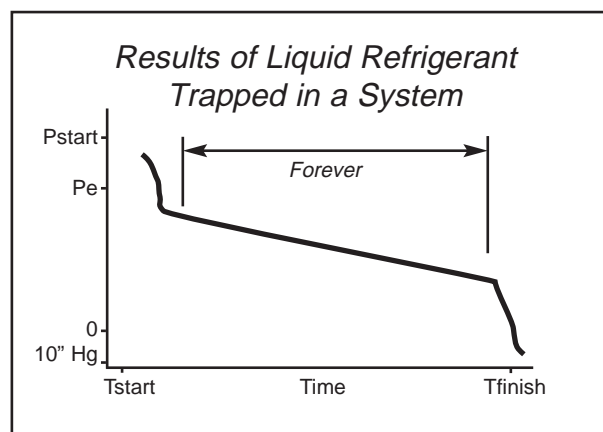

## HOSES AND VALVES

Hoses and Schraeder valves have a large impact on recovery speed. In general, the larger the hose, the less friction on the flow of refrigerant, the quicker the recovery time. Many contractors are now using 9.5mm (3/8") lines for the input to the recovery machine, even those lines originating out of 6.3mm(1/4") fittings, and the shortest hose possible.

Schraeder valves must be removed from the connection prior to an expedient recovery. Most wholesalers sell a tool for removing these cores, while keeping the connection sealed. The core depressor, in the end of the hose, should also be removed. These two items can turn a 20 minute job into one that goes on for hours. So, be sure to remove the Schraeder valves and core depressors before every recovery job.

Another hose consideration is the little rubber grommet at the end of the hose that makes a seal with the flare fitting. We've seen these seals so worn and deformed that when the hose is connected to the flare fitting the grommet virtually seals off the connection.

# HELPFUL HINTS FOR REFRIGERANT RECOVERY - cont.

This is probably never noticed in charging, because the pressure opens the grommet, but during recovery (or with suction) the deformed grommet severely restricts the flow of refrigerant.

## REFRIGERANT RECYCLING

Current regulations state that used refrigerant shall not be sold, or used in a different owner's equipment, unless the refrigerant has been laboratory analyzed and found to meet the requirements of ARI 700 (latest edition). As a result, recycling and verifying ARI 700 conformance isn't economically justified in most cases. It's still a great idea to do as much cleaning of refrigerant going back into the same system (or owners system) as possible. We recommend using the largest, high-acid capacity filter, that are economically feasible. Put these filters on the suction or inlet side of the recovery unit. Change filters often.

The recovery of large amounts of liquid refrigerant can sometimes carry with it large quantities of oil, if the system being serviced doesn't have an adequate oil separator installed. If this recovered refrigerant isn't going to be liquid charged back into the same system, you might want to separate the refrigerant from the oil in order to measure the oil (to know how much oil to charge back into the system). Refrigerant sent back for reclaim does not need to have the oil removed. One of the simplest and most cost effective ways to achieve this is to use a 13.6kg or 22.7kg (30 or 50 lb.) tank in line with your recovery machine. Connect the system to the liquid port of the tank, then from the vapor port of the tank connect to the input of your recovery machine. A second tank, for storing refrigerant, should then be connected to the output of the recovery machine. If you encounter large amounts of liquid you will need to put a band heater around the first tank. When the recovery job is complete the oil can be removed, from the first tank, by applying a small amount of pressure, using nitrogen, to one of the ports and extracting the oil from the other. If you are going to remove the oil from the vapor port you will need to turn the tank upside down. Always wear safety glasses when performing this operation as the oil may be acidic and could cause severe burning.

## KEEPING THE DIRT OUT

During the recovery process your recovery machine can be exposed to debris that can, potentially, damage it. This includes brazing spatter and copper/ brass slithers. Further contamination can be introduced from the refrigerant storage tanks. To prolong the life of your recovery machine, **always use an inline filter at the inlet Port.**

Whenever you are charging a system from a recovery cylinder it is a good idea to use an in-line filter to protect the system from contamination. Again, change your in-line filters often.

## GETTING THE LIQUID OUT

See diagram on page 13 of this manual

Push/pull is a method of removing bulk liquid from a system using the pressure differential created by the recovery machine. Push-pull will generally not work on smaller systems because there is no bulk liquid reservoir to create a siphon from.

Push-pull is mostly used on systems with a receiver tank or those with greater than 9.1kg (20 lbs.) of refrigerant, or when transferring from one tank to another. The rate of liquid transfer is very much dependent on hose size, with larger hoses providing much better throughput.

Another trick is to cool the tank, if it's partially filled, prior to or during recovery. This operation will lower the pressure in the storage tank and therefore speed up recovery. There must be a minimum of 2.3kg (5 lbs) of liquid refrigerant in the tank you wish to chill. This operation can be performed prior to or during the recovery. See the two set up diagrams and procedures on pages 13-14 of this manual.

There is nothing magic here, you are simply using your recovery machine to make a refrigerator where the tank is the evaporator. By throttling the output valve, you're effectively creating a capillary tube or an expansion device, but you need to adjust the back pressure to suit the conditions and the refrigerant. Five to ten minutes of chilling can produce some very dramatic tank cooling, depending on the conditions. If there are any non condensables in the tank this process will not work. The greater the quantity of refrigerant in the tank the longer the process will take.

# OPERATING YOUR ProVax™

## ProVax™ Control Panel Overview

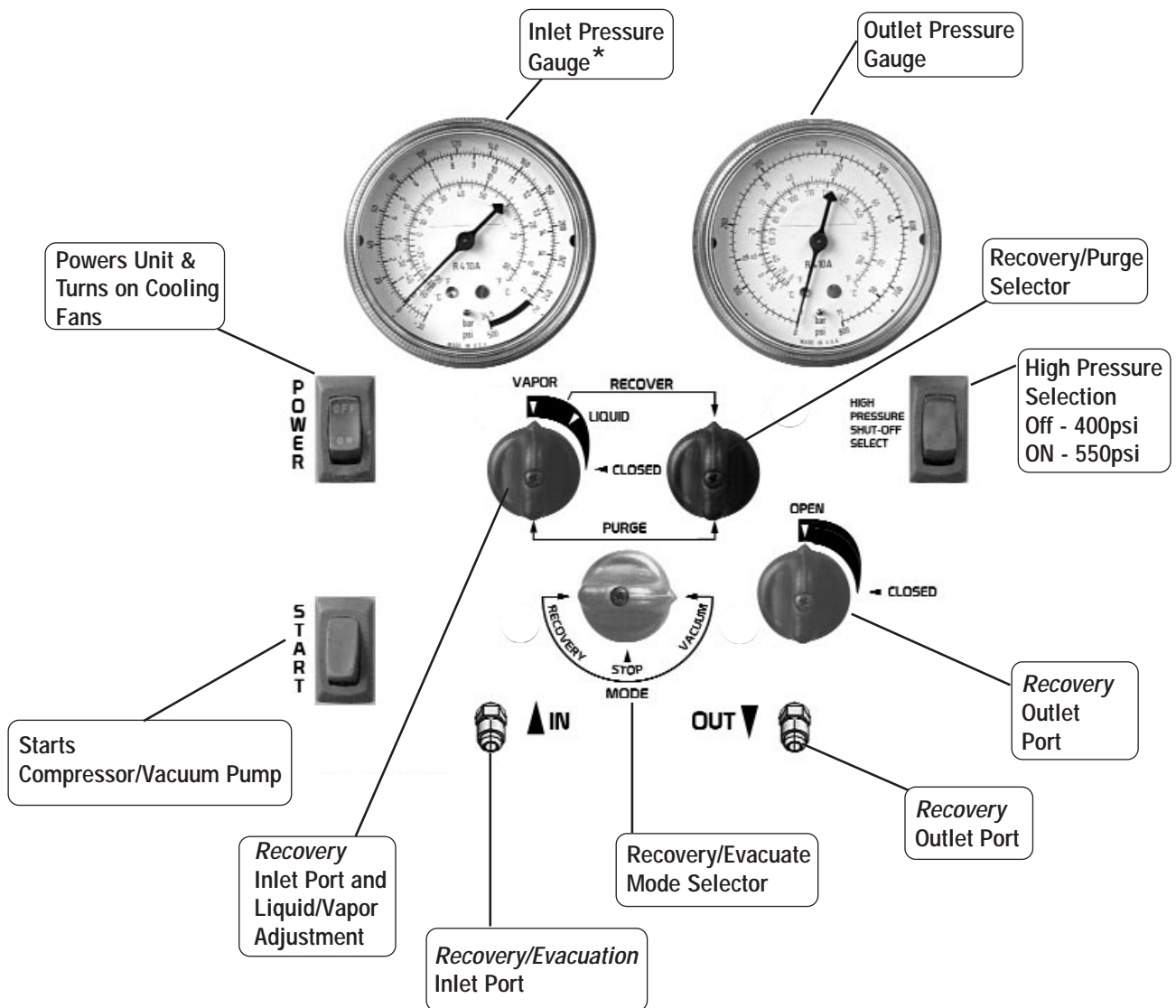

Note: \*Promax recommends the use of either the Robinair 14010A or 14830A Thermistor Vacuum Gauge to monitor vacuum level

# OPERATING YOUR ProVax™

## PROCEDURE FOR NORMAL SYSTEM RECOVERY

1. Inspect the ProVax thoroughly to insure that it is in good operating condition.
  2. Ensure that the outlet valve/knob (RED) and the inlet valve/knob (BLUE) on the ProVax are in the closed positions.
  3. Set the "Mode" valve/knob (Yellow) to "Recovery"
  4. Set the "Recover/Purge" valve/knob (BLACK) to "Recover".
  5. Connect ProVax to the system being serviced, making sure all connections are correct and tight. (see set-up diagram).
  6. Open the liquid port of the recovery cylinder (always open valves slowly to check hoses and connections for leaks).
  7. Open the liquid port on your manifold gauge set. Opening the liquid port will remove the liquid from the system first, greatly reducing the recovery time. (after the liquid has been removed, open the manifold vapor port to finish evacuating the system).
- Note: The ProVax uses an "oil-less" compressor during recovery. It is lubricated with the oil suspended in the refrigerant. Ensure there is refrigerant up to the ProVax inlet valve prior to turning on the unit.
8. Connect your ProVax to Power.
  9. Place "High Pressure Shut Off Select" switch in the desired position.
- Note: When the High Pressure Select switch is in the ON position, the unit will shut off at 550 PSI (for R410A). In the OFF position it will shut off at 400 PSI.
- a. Turn on the "Power" switch. You should hear the cooling fans running
  - b. Press the "Start" switch. This momentary switch will start the compressor/motor.
10. Open the output valve/knob (RED) on the ProVax.
  11. Slowly open the input valve/knob (BLUE) on the ProVax.
    - a. If the compressor starts to knock, slowly throttle back the input valve/knob until the knocking stops.
    - b. If the input valve was throttled back, it should be fully opened once the liquid has been removed from the system (the manifold gauge set vapor port should also be opened at this time).
  12. The ProVax will automatically stop after the refrigerant has been removed and it reaches 10" to 20" hg vacuum.
- Note: Anytime you want to pause an operation, you can stop the unit by turning the "MODE" valve/knob (YELLOW) to "Stop".
- Note: To restart, turn the Recover/Purge valve/knob (BLACK) to "Recover" and the input valve/knob (BLUE) to "Closed" and press the "Start" switch.
13. Close the manifold gauge set's vapor and liquid ports.
  14. Turn the ProVax input valve/knob (BLUE) to the "Closed" position.
  15. Proceed with the Self Purge and Vacuum. (see Self Purge/Vacuum procedure on page 12).
- Note: Always purge the ProVax after each use. Failure to purge the remaining refrigerant from the ProVax could result in the acidic degradation of internal components, ultimately causing premature failure of the unit.

# OPERATING YOUR ProVax - cont.

## PROCEDURE FOR SELF PURGE

1. Ensure the "MODE" valve/knob (YELLOW) is in the "Recovery" position.
2. Ensure the Recover/Purge valve/knob (BLACK) is the "Recover" position.  
Note: will be moved to "Purge" position after start.
3. Turn the input valve/knob (BLUE) to Purge
4. Restart the ProVax.
  - a. Power "On"
  - b. Press "Start"
5. Turn the Recover/Purge valve/knob (BLACK) to the "Purge" position.
6. Open the Output valve/knob (RED)
7. The ProVax will automatically stop after the unit is purged and it reaches 10" to 20" hg vacuum.
8. Close the recovery tank valves and close the Outlet valve/knob (RED) and Inlet valve/knob (BLUE) on the ProVax.
9. Turn the ProVax "Power" switch "Off".
10. Return the Recover/Purge valve/knob (BLACK) knob to the "Recover" position.
11. Turn the Inlet valve/knob (BLUE) to the "Closed" position.
12. Disconnect and store all hoses.

Note: It is recommended that the in-line filter/dryer be replaced after every recovery job.

## PROCEDURE FOR PULLING A VACUUM

**⚠WARNING:** Do not expose the inlet-port of the ProVax to pressure while in the Vacuum Mode

1. Turn BLUE valve/knob to "Closed" position
2. Turn Recover/Purgevalve/knob (BLACK) to "Recover"
3. Turn output valve/knob (RED) to "Closed"
4. Turn "MODE" valve/knob (YELLOW) to "Vacuum" position
5. Start unit.
  - a. Power "On"
  - b. Press "Start"
6. Run until desired vacuum is reached
7. To stop, rotate "MODE" valve/knob (YELLOW) to the "Stop" position.
8. Cap inlet port to prevent contamination.

## DIAGRAM FOR REFRIGERATION RECOVERY

THIS IS THE FASTEST METHOD FOR RECOVERING VAPOR REFRIGERANT

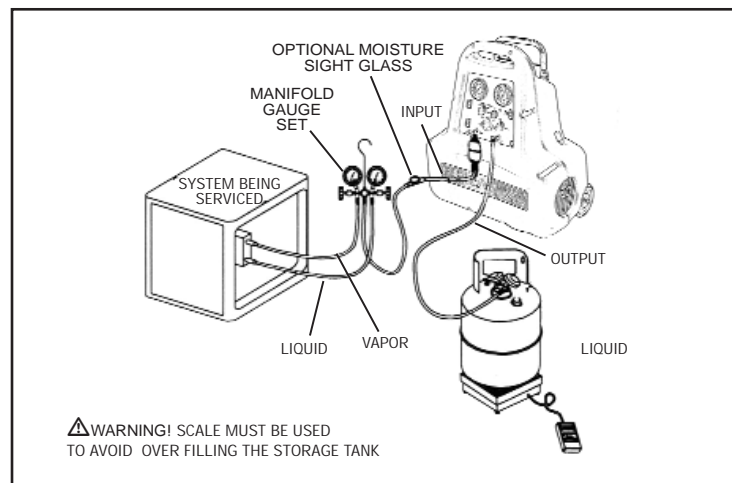



# DIAGRAM FOR "PUSH/PULL" METHOD

Push/pull method only works with large systems where the liquid is readily accessible. Do not use this method on systems that contain less than 6.8 kg (15 lbs.) as it may not work.

The sight glass is used to provide a method of determining the moisture content and quality of a system's refrigerant.

**⚠ CAUTION:** When using the "Push/Pull" method, once the siphon is started, it can continue and overflow the storage tank even if the tank is equipped with a float level sensor. The siphon can continue even when the machine is turned off. You must manually close the valves on the tank and the unit to prevent overflowing of the recovery tank.

1. Close INPUT and OUTPUT valves
  2. Turn MODE knob to "RECOVERY"
  3. Turn RECOVERY/PURGE knob to "RECOVER"
  4. Start machine
  5. Open INPUT valve to the "VAPOR" position and OUTPUT valve to "OPEN"
  6. When the refrigerant scale stops rising, close all ports
- CAUTION:** Do not overfill tank
7. Turn MODE knob to "STOP"
  8. Switch off machine

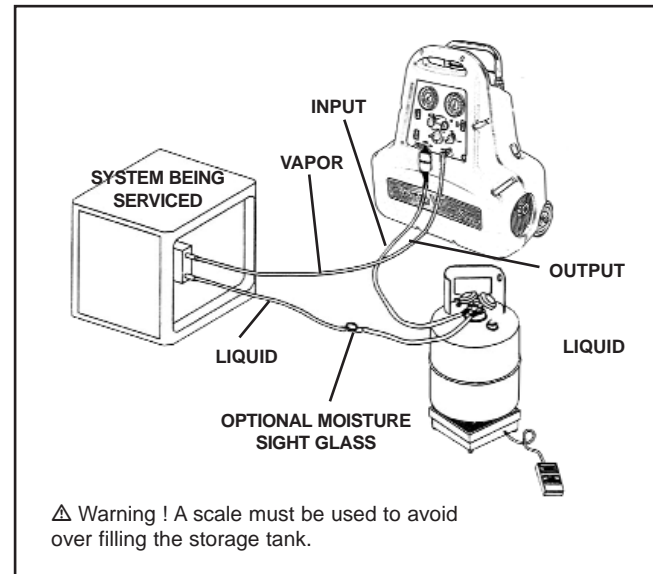

## SET-UP DIAGRAM FOR TANK PRE OR SUB COOLING PROCEDURE

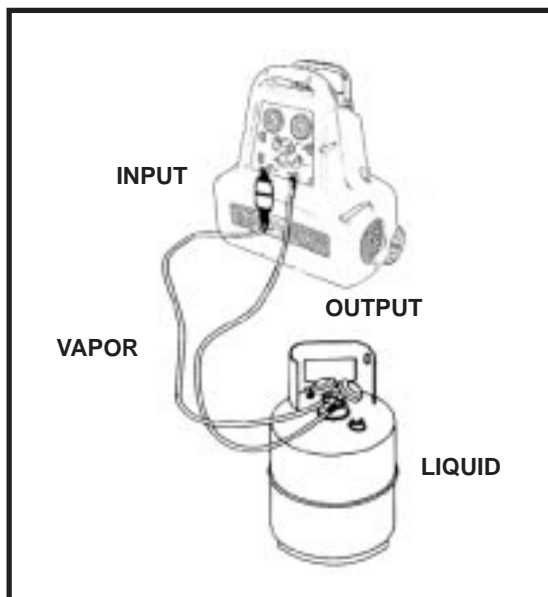

See page 9 for more information on Sub Cooling.

Note: To begin this process you must have a **minimum of 5 lbs.** of liquid refrigerant in the tank. If this is not the case, using a fully evacuated empty tank will help you achieve the fastest recovery time.

1. Close INPUT and OUTPUT valves
2. Turn MODE knob to "RECOVERY"
3. Turn RECOVERY/PURGE knob to "RECOVER"
4. Start machine
5. Open INPUT valve to the "LIQUID" position
6. Throttle the OUTPUT valve so that the output pressure is 100 psi greater than the input pressure, but never more than 300 psi
7. Run until tank is cold



## OPTIONAL RECOVERY/TANK PRE OR SUB COOLING FOR FIXED HOSE SET-UP

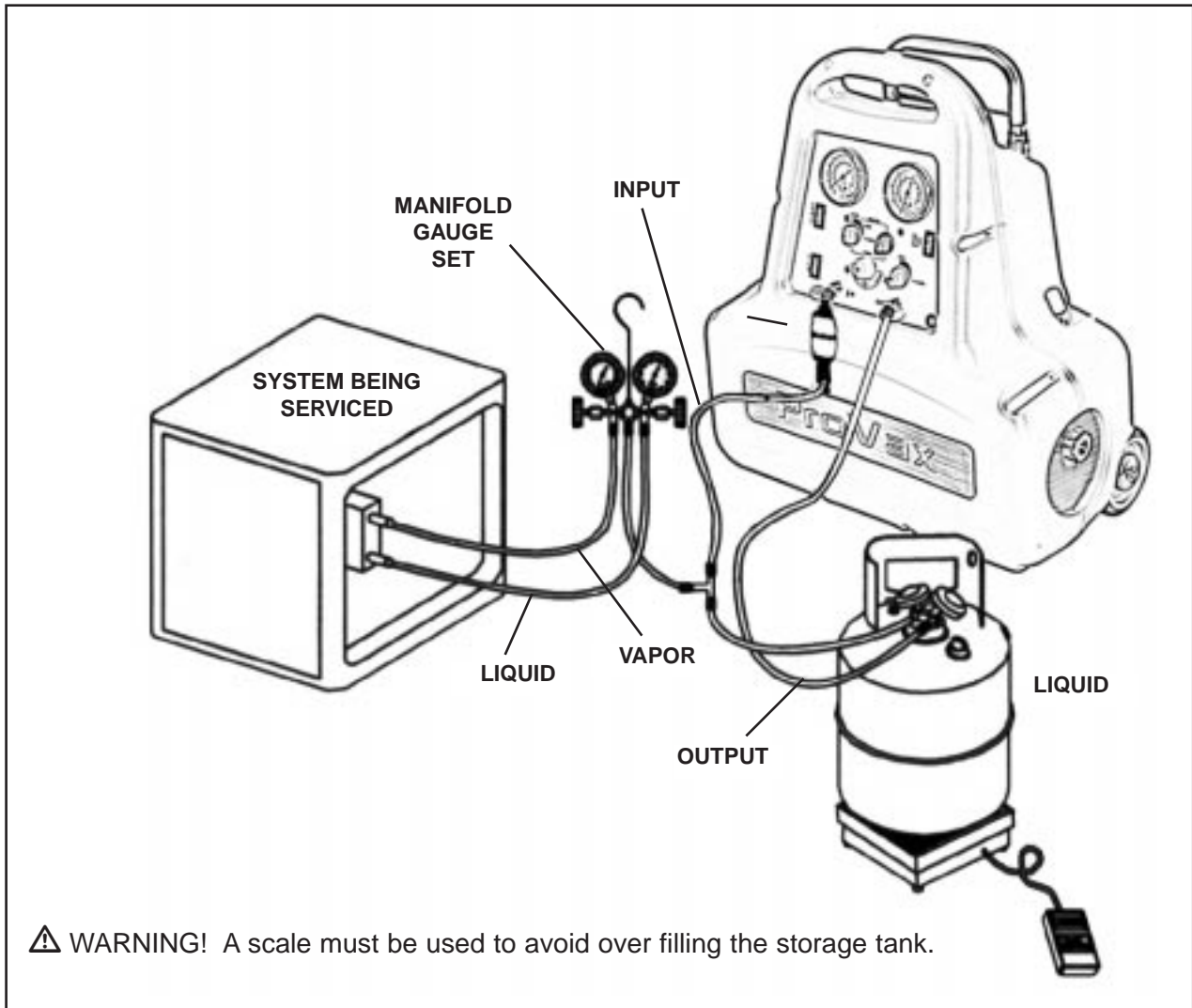

**⚠ WARNING!** A scale must be used to avoid over filling the storage tank.

### **NORMAL RECOVERY:**

Tank Vapor valve is closed

### **TANK PRE OR SUB COOLING:**

Tank Vapor valve is open and both manifold gauge set valves are closed.

# VACUUM PUMP MAINTENANCE

## Vacuum Pump Oil

For maximum performance, Promax recommends changing vacuum pump oil after each use.

The condition and type of oil used in any high vacuum pump are extremely important in determining the ultimate attainable vacuum. Promax recommends the use of Robinairs Premium High Vacuum Pump Oil.

This oil has been specifically blended to maintain maximum viscosity at normal running temperatures and to improve cold weather starts.

Robinair Premium High Vacuum Pump Oil is available in handy quart containers or in convenient gallon containers. Order by part number:

13119 — Pint (shipped 12 pints per case)

13203 — Quart (shipped 12 quarts per case)

13204 — Gallon (shipped 4 gallons per case)

## VACUUM PUMP OIL CHANGE PROCEDURE

1. Warm up the vacuum pump by running:
  - a. Place a cap on the inlet port
  - b. Turn Mode knob (Yellow) to "Vacuum"
  - c. Turn on "Power" switch
  - d. Press "Start" switch
  - e. Run for 2 minutes and then turn off power.

Note: ProVax inlet gauge does not indicate vacuum level. Use a separate vacuum gauge to observe vacuum level.

2. Unplug unit from power source
3. Place ProVax on a raised surface, with oil drain plug on the bottom of the unit exposed
4. Place a suitable container under drain plug
5. Remove OIL FILL cap
6. Remove OIL DRAIN cap
7. Drain oil into container until flow of oil has completely stopped
8. Replace the OIL DRAIN cap
9. Fill oil reservoir with new vacuum pump oil until oil just shows at of bottom of the sight glass. The approximate oil capacity is 15 ounces.
10. Be sure the inlet port is capped and TURN ON vacuum pump (see step 1)
11. Allow pump to run for one minute, then check the oil level. If the oil is below the sight glass OIL FILL line, add oil slowly (while pump is running) until the oil reaches the OIL LEVEL line.
12. Replace the OIL FILL cap, making sure the inlet is capped and the drain cap is tight.

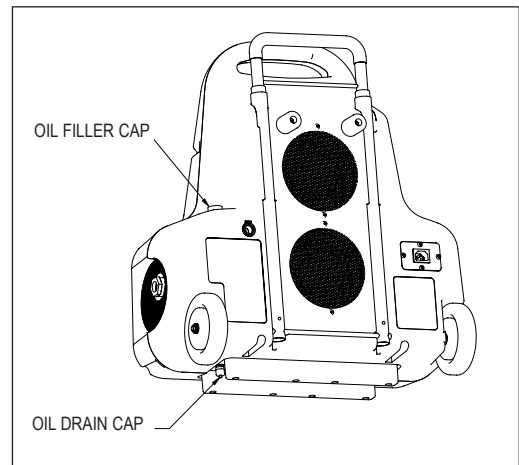

# ProVax™ DIAGRAM

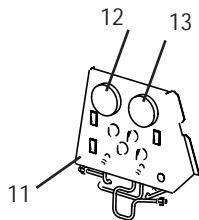
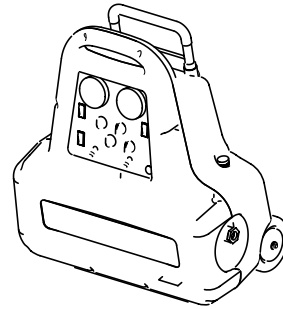
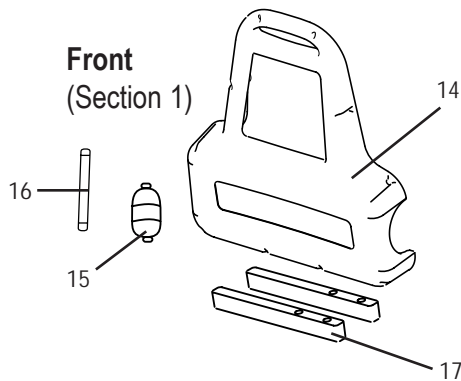

**Control Panel**  
(Section 2)

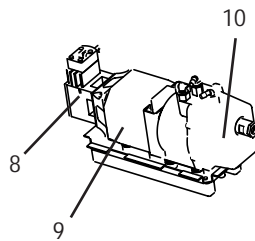

**Motor/Compressor/Pump**

(Section 3) (Note: For compressor Repair Kits see page 17)

## Section 1 - ProVax Front:

Item.#	Part#	Description
(14)	527075	Front & Rear Case, plastic (set)
(15)	100343	Filter Drier
(16)	100345	4" Blue Hose
(17)	527374	Rubber Foot

## Section 2 - ProVax Control Panel:

Item.#	Part#	Description
(11)	527080	Front Panel
(12)	GA1500	Pressure Gauge, 500 Psi
(13)	GA0800	Pressure Gauge, 800 Psi
N/S	GA1000	Gauge Lens
N/S	528160	Inlet & outlet Fitting 45 degree
N/S	NB6501	Inlet & outlet Fitting Protection Cap
N/S	EL1309	Start Switch, momentary
N/S	EL1310	ON-OFF Switch
N/S	527376ASM	Manifold Assembly
N/S	EL2800	Pressure Sensor (400psi)
N/S	EL2802	High Pressure Sensor (500psi)
N/S	113726	Vacuum Switch (13in Hg)
N/S	120106	Vacuum Protection Switch
N/S	100122	Black Knob
N/S	100123	Blue Knob
N/S	100124	Red Knob
N/S	527845	Yellow Knob

## Section 3 - ProVax Motor/Compressor/Vacuum Pump:

Item.#	Part#	Description
(8)	527835ASM	Compressor Assembly
(9)	525935	Motor, 115V, 60Hz
(10)	527834ASM	Vacuum Pump Assembly
N/S	527069ASM	Vacuum Pump Clutch Assy
N/S	528167ASM	Compressor Clutch Assy.
N/S	527086	Vacuum Pump & Motor "Vibration" Mount

## Section 4 - ProVax Back:

Item.#	Part#	Description
(1)	527075	Front & Rear Case, plastic (set)
(2)	100478	Condenser
(3)	527073	Handle
(4)	527074	Wheel
N/S	529931	Retaining ring, wheel
N/S	527077	Axle, wheel
(5)	EL1817	Axial Fan
(6)	EL1412	Start Capacitor
(7)	110969	Oil Filler Cap
N/S	NB6501	Oil Drain Cap
N/S	EL1500	Relay
N/S	527084	Compressor Grill
N/S	527085	Vacuum Pump Grill
N/S	527076	Fan Grill
N/S	529925	Bumper
N/S	111443	Power Cord, 115V/60Hz

# REPLACEMENT KITS

<b>PART#</b>	<b>DESCRIPTION</b>
13119	PREMIUM HIGH VACUUM PUMP OIL, PINT BOTTLE (case of 12)
15367	VACUUM PUMP SEAL REPLACEMENT KIT
KT3302	PISTON SEAL REPLACEMENT (middle section of compressor)
KT3303	VALVE REPLACEMENT KIT (top section of compressor)
KT3307	COMPRESSOR REPAIR KIT (all three sections of compressor)
KT3308	SHAFT REPLACEMENT KIT (bottom section of compressor)

# RECOMMENDED ACCESSORIES

<b>PART#</b>	<b>DESCRIPTION</b>
KT-5002	80% CAPACITY TANK SENSING KIT
RGT30	30 LB RECOVERY TANK (350 psi working pressure) with capacity sensor
RGT30NS	SAME AS RGT30, WITHOUT SENSOR
RGT50	50 LB RECOVERY TANK (350 psi working pressure) with capacity sensor
RGT50NS	SAME AS RGT50, WITHOUT SENSOR
RGT50HP	50 LB RECOVERY TANK, HIGH PRESSURE (400 psi working pressure) with capacity sensor
10994	HEATER BLANKET
ADS-100	REFRIGERANT SCALE, 200LB CAPACITY, WITH REMOVABLE PLATFORM
41670	HIGH PRESSURE MANIFOLD SET, 60" COLOR CODED HOSES, FOR R410A
416330	TWO WAY MANIFOLD SET, 72" COLOR CODED HOSES, FOR R22 AND R134a
14830A	THERMISTOR VACUUM GAUGE
16910	REFRIGERANT IDENTIFIER
16440	CORDLESS RECHARGEABLE 30-LED LIGHT
4650	MIRROR AND MAGNET SET
TIFZX-1	HEATED PENTODE™ REFRIGERANT LEAK DETECTOR

NOTE: For details see: [www.AdvancedTestProducts.com](http://www.AdvancedTestProducts.com)

# ProVax™ WIRING DIAGRAM

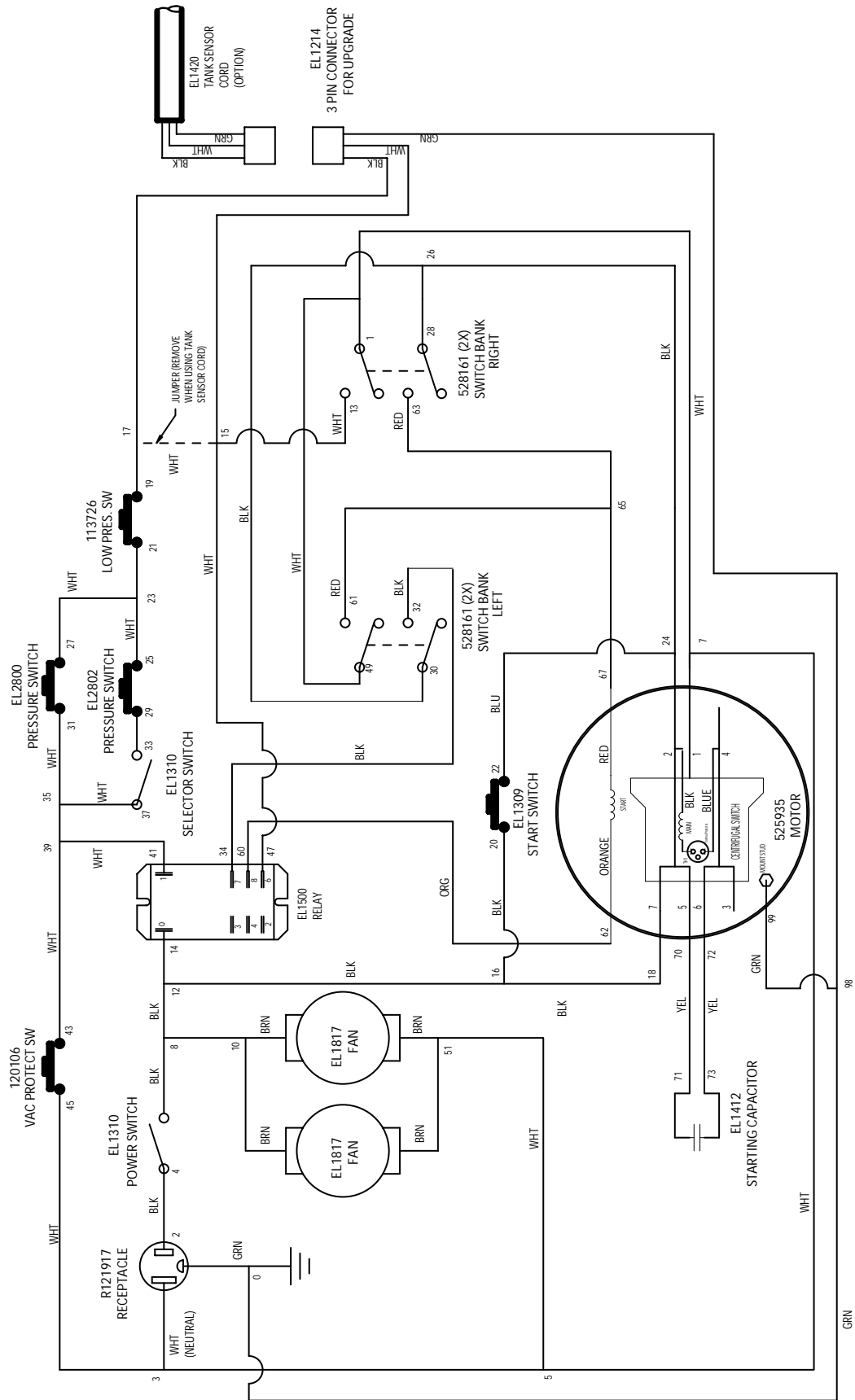

## INSTALLATION OF OPTIONAL 80% TANK SHUT-OFF KIT CAPACITY SENSING COMPONENTS (P/N:KT-5002)

⚠ **WARNING:** Prior to performing any type of maintenance work on your ProVax, insure that it is disconnected from the power supply before you begin.

**NOTE:** Refer to the wiring diagram on page 17 during the installation of your kit.

1. Disconnect your ProVax from the power source.
2. Remove the case fasteners and separate the front half of the ProVax.
3. Identify white "jumper wire," located below hole in lower right corner of the front panel, designated for the tank sensor cord.

Note: Jumper wire identified with a tag.

4. Disconnect jumper where tagged and secure it to nearest wire bundle, using wire tie provided.
5. Route tank sensor cord (EL1420) through the hole in the front panel, passing the "tank connector" end through from the backside.
6. Secure the tank sensor cord in the hole with the strain relief grommet provided.
7. Connect the 3-pin male connector (white) supplied with the KT5002 to its counterpart, pre-wired inside your ProVax.
8. Secure any loose wiring with the wire ties provided.
9. Replace the plastic case halves and fasteners.

10. To test the installation:

- a. Attempt to start the ProVax without the sensor cord attached to a tank. The ProVax's compressor should not start up.
- b. Turn the ProVax off and attempt to start the ProVax with the sensor tank connected to a tank. The unit should function normally. Disconnecting the sensor cord while the unit is running should cause the unit to shut down.

11. If your unit does not function as described above, DISCONNECT the ProVax from the power supply, and re-check your connections per the steps above and the wiring diagram on page 17.



# TROUBLESHOOTING YOUR ProVax

## SAFETY FIRST

Read and understand all safety information contained in this manual before servicing the unit.

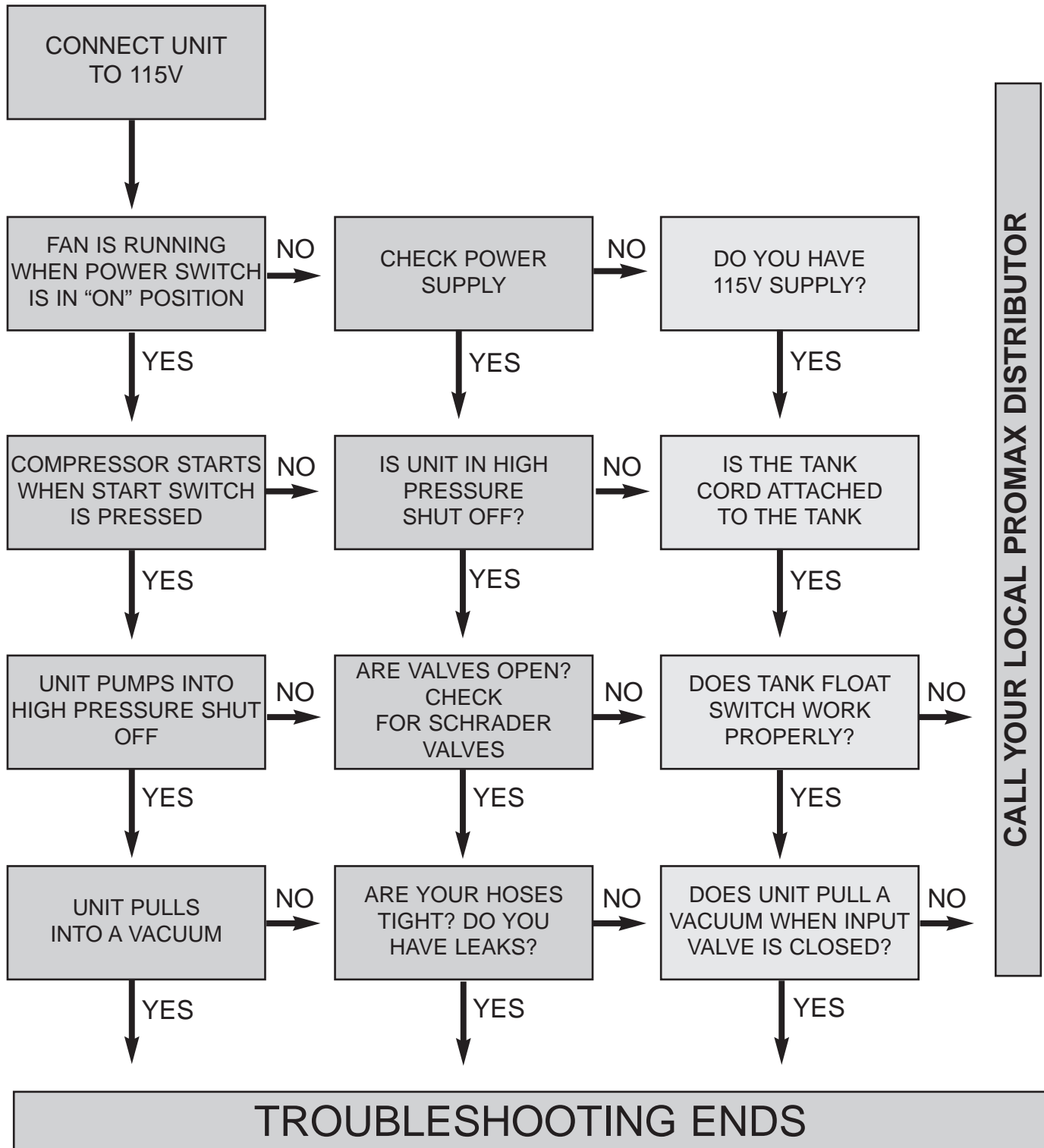

CALL YOUR LOCAL PROMAX DISTRIBUTOR

# TROUBLESHOOTING GUIDE

## Vacuum Pump

Your CoolTech® pump has been designed for dependable use and long life. If something should go wrong, however, the following guide will help you get the pump back in service as quickly as possible.

If disassembly of the pump is required, please check your warranty. The warranty may be voided by misuse or customer tampering, which results in the pump being inoperable.

### **Oil Leakage**

1. Be sure the oil is not a residual accumulation from spillage, etc.
2. If leakage exists, the module cover gasket or the shaft seal may need replacing. Follow the instructions supplied with the Seal Replacement Kit, part number 15367. If leakage exists in the area of the oil drain plug, you may need to reseal the plug using a commercial pipe thread sealer.

### **Failure To Pull A Good Vacuum**

1. Be sure the vacuum gauge and all connections are in good condition and leak-free. You can confirm leakage by monitoring the vacuum with a thermistor gauge while applying vacuum pump oil at connections or suspected leak points. The vacuum will improve briefly while the oil is sealing the leak.
2. Be sure the pump oil is clean. A badly contaminated pump may require several oil flushes. See OIL CHANGE PROCEDURE.  
Note: Use only high vacuum pump oil such as Robinairs' Premium High Vacuum Pump Oil. Other oils will prevent pull-down to a deep vacuum.
3. Be sure the oil is at the proper level. For maximum pump operation, the oil must be even with the OIL LEVEL line on the sight glass when the pump is running. See OIL CHANGE PROCEDURE. Do not overfill —operating temperatures will cause the oil to expand so it will appear at a higher level than when the pump is not running. To check the oil level, start the pump with the inlet capped. Check the oil level in the sight glass. Add oil if necessary.

# SPECIFICATIONS

	Recovery Section	Vacuum Section		
Refrigerants	Cat. III: R-12, R-134a, R-401C, R-406A, R-500, Cat. IV: R-22, R-401A, R-401B, 402B, R-407C, R-407D, R-408A, R-409A, R-411A, R-411B, R-412A, R-502, R-509, Cat. V: R-402A, R-404A, R-407A, R-407B, R-410A, R-507	same		
Power (+/- 10%)	115VAC 60 Hz	same		
Motor	1/2 HP, AC, cap start, inductive run, brushless			
Motor Speed	1725 RPM	same		
Current Draw	Full Load: 10 amps @ 115 VAC; Locked Rotor: 23.1 amps	n/a		
Compressor Type	Proprietary "Oil-less," air cooled, piston style, Kynar™ poppet valves, triple teflon™ ceramic polymer piston seals	n/a		
High Pressure Shut-off	Selectable: 400 or 550 psi	n/a		
Recovery low pressure Cut-Out Switch	13in Hg (+/- 3)	n/a		
Refrigerant Recovery Rate: Push/Pull	<b>Refrigerant Class</b>			n/a
	<b>Category III</b>	<b>Category IV</b>	<b>Category V</b>	
	8.00 Lbs./min. 3.63 kg/min	9.52 Lbs./min. 4.32 kg/min	10.82 Lbs./min. 4.91 kg/min.	
	3.46 Lbs./min. 1.57 kg/min.	3.99 Lbs./min. 1.81 kg/min.	4.08 Lbs./min. 1.85 kg/min.	
Refrigerant Recovery Rate: Liquid	3.46 Lbs./min. 1.57 kg/min.	3.99 Lbs./min. 1.81 kg/min.	4.08 Lbs./min. 1.85 kg/min.	n/a
Refrigerant Recovery Rate: Vapor	0.24 Lbs./min. 0.11 kg/min.	0.33 Lbs./min. 0.15 kg/min.	0.35 Lbs./min. 0.16 kg/min.	n/a
Vacuum Pump Type	n/a	Offset Rotary Vane		
Stages	n/a	2 Stage		
Free Air Displacement	n/a	6 CFM		
Factory Micron Rating	n/a	20 microns		
Approx. Oil Capacity	n/a	15 oz.		
Maximum Vacuum Pump Protection Cut-off Switch	n/a	25psi (+ / - 5)		
Operating Temp.	32° F to 155° F	same		
Dimensions	25" H X 22" W X 10" D	n/a		
Weight	57 lbs	n/a		
EPA Certification	ARI-740 by UL® (control no.8EA7)	n/a		

# FULL ONE YEAR WARRANTY

**MFG #** \_\_\_\_\_

Promax products are warranted to be free from defects in workmanship and materials for a period of one year from date of purchase.

## **THE FOLLOWING RESTRICTIONS APPLY:**

1. The warranty applies to products in normal use only, as described in the operating manual. The product must also be serviced and maintained as described therein.
2. If the product fails, it will be replaced at the option of Advanced Test Products, Inc. (ATP)
3. Warranty service claims are subject to factory inspection for product defect(s). If during the warranty evaluation it is determined that a filter has not been used or that the filter was not properly maintained or that the machine has been used in any way other than the purpose for which it was designed, ATP, reserves the right to void the warranty.
4. All warranty claims must be made within the warranty period. Proof of purchase must be supplied . This warranty is non-transferable.
5. Please note that the warranty does not apply if the product or product part is damaged by accident, misuse, tampered with or modified in any way.
6. Normal wear items (seals, filters, etc.) are specifically excluded from warranty, unless found by Promax to be defective.

## **WARRANTY SERVICE**

This warranty is given by ADVANCED TEST PRODUCTS, INC.

Service under this warranty must be obtained by the following steps:

1. Outside the U.S.A. contact your local Promax Distributor.
2. Inside the U.S.A. call 1.800.327.5060 or 954-499-5400 for a return material authorization (RMA) number.

# THE UNITED STATES ENVIRONMENTAL PROTECTION AGENCY (EPA) REFRIGERANT RECOVERY AND RECYCLING DEVICE ACQUISITION CERTIFICATION FORM

EPA regulations have required establishments that service or dispose of refrigerant or air conditioning equipment to certify that they have acquired recovery and recycling devices that meet the EPA standards for such devices since August 12, 1993. To certify that you have acquired equipment, please complete this form according to the instructions and mail it to the appropriate EPA Regional Office. BOTH THE INSTRUCTIONS AND MAILING ADDRESS CAN BE FOUND ON THE NEXT PAGE OF THIS MANUAL.

## Part 1: ESTABLISHMENT INFORMATION

## UNIT STORAGE ADDRESS

<i>Name of Establishment</i>		
<i>Street</i>		
<i>City</i>	<i>State</i>	<i>County</i>
<i>Zip Code</i>	<i>(Area Code)</i>	<i>Telephone Number</i>

<i>Name of Establishment</i>		
<i>Street</i>		
<i>City</i>	<i>State</i>	<i>County</i>
<i>Zip Code</i>	<i>(Area Code)</i>	<i>Telephone Number</i>

NUMBER OF SERVICE VEHICLES BASED AT ESTABLISHMENT

## Part 2: REGULATORY CLASSIFICATION

Identify the type of work performed at your establishment. Check all boxes that apply.

Type A - Service small appliances.

Type B - Service refrigeration or air conditioning equipment other than small appliances.

Type C - Dispose of small appliances

Type D - Dispose of refrigeration or air conditioning equipment other than small appliances.

## Part 3: DEVICE IDENTIFICATION

Name of Device Manufacturer	Model #	Month/Year	Mfg# (if any)	Self Contained

## Part 4: SIGNATURE

I certify that the establishment named in part 1. has acquired the refrigerant recovery or recycling devices listed in part 3. and that this equipment will be properly used in service (and/or) disposing of appliances. I also certify that the information supplied herein is correct and true.

Signature of owner / Responsible Officer	Date	Name (please print)	Title
--	------	---------------------	-------

Public reporting burden for this collection of information is estimated to vary from 20-60 minutes per response with an average of 40 minutes per response including time for reviewing instructions, searching existing data sources, gathering and maintaining the data needed and completing the collection of information. Send comments regarding the burden estimate or any other aspect of this collection of information, including suggestions for reducing the burden to: Chief information Policy Branch EPA, 401 M St. S.W. (PM223Y), Washington, DC 20460 and to the Office of information and Regulatory Affairs, Office of Management and Budget, Washington, DC 20503 marked Attention, Desk Officer for EPA.

DO NOT SEND THIS FORM TO THE ABOVE ADDRESSES. ONLY SEND COMMENTS TO THESE ADDRESSES

# INSTRUCTIONS EPA REGIONAL OFFICES

Part 1. Please provide the name, address and telephone number of the establishment where the refrigerant recovery or recycling device(s) is (are) located. Please complete one form for each location. State the number of vehicles based at this location that are used to transport technicians and equipment to and from service sites.

Part 2. Check the appropriate box for the type of work performed by technicians who are employees of the establishment. The term "small appliance" refers to any of the following products that are fully manufactured, charged and hermetically sealed in a factory with five or less pounds of refrigerant:

Refrigerators or freezers designed for home use, room air conditioners (including window air conditioners and packaged thermal air conditioners), packaged thermal heat pumps, dehumidifiers, under-the-counter ice makers, vending machines and drinking water coolers.

Part 3. For each recovery or recycling device acquired, please list the name of the manufacturer of the device and (if applicable) its model number and manufacturer number. If more than 8 devices have been acquired please fill out an additional form and attach it to the first one.

Recovery devices that are self-contained should be listed first and should be identified by checking the box in the last column on the right. A self-contained device is one that uses its own pump or compressor to remove refrigerant from refrigeration or air conditioning equipment. On the other hand, system dependent recovery devices rely solely upon the compressor in the refrigeration or air conditioning equipment and/or upon the pressure of the refrigerant inside the equipment to remove the refrigerant.

If the establishment has been listed as Type B and/or Type D in Part 2, then the first device listed in Part 3 must be a self-contained device and identified as such by checking the box in the last column on the right.

If any of the devices are homemade, they should be identified by writing "homemade" in the column provided for listing the name of the device manufacturer. Homemade devices can be certified for establishments that are listed as Type A or Type B in Part 2 until (six months after promulgation of the rule). If a Type C or Type D establishment is certifying equipment after (six months after promulgation of the rule), then it must not use these devices for service jobs classified as Type A or Type B.

Part 4. This form must be signed by either the owner of the establishment or another responsible officer. The person who signs is certifying that the establishment has acquired the equipment, that the establishment is complying with Section 608 regulations and that the information provided is true and correct.

**Send your form to the EPA office listed under the state or territory in which your establishment is located.**

## **CONNECTICUT, MAINE, MASSACHUSETTS, NEW HAMPSHIRE, RHODE ISLAND, VERMONT**

CAA 608 Enforcement Contact: EPA Region 1.  
Mail Code APC, One Congress Street, John F. Kennedy Federal Building, Boston, MA 02203-0001  
Phone: (617) 565-3420

## **NEW YORK, NEW JERSEY, PUERTO RICO, VIRGIN ISLANDS**

CAA 608 Enforcement Contact: EPA Region 2.  
290 Broadway, New York, NY 10007-1866  
Phone: (212) 637-3000

## **DELAWARE, DISTRICT OF COLOMBIA, MARYLAND, PENNSYLVANIA, VIRGINIA, WEST VIRGINIA**

CAA 608 Enforcement Contact: EPA Region 3. Mail Code 3AT21, 1650 Arch Street, Philadelphia, PA 19103-2029  
Phone: (215) 566-5000

## **ALABAMA, FLORIDA, GEORGIA, KENTUCKY, MISSISSIPPI, NORTH CAROLINA, SOUTH CAROLINA, TENNESSEE**

CAA 608 Enforcement Contact: EPA Region 4. Mail Code APT-AE, 100 Alabama Street, SW, Atlanta, GA 30303  
Phone: (404) 562-8357

## **ILLINOIS, INDIANA, MICHIGAN, MINNESOTA, OHIO, WISCONSIN**

CAA 608 Enforcement Contact: EPA Region 5. Mail Code AT18J, 77 West Jackson Blvd., Chicago, IL 60604-3507  
Phone: (312) 353-2000

## **ARKANSAS, LOUISIANA, NEW MEXICO, OKLAHOMA, TEXAS**

CAA 608 Enforcement Contact: EPA Region 6. Mail Code 6T-EC, Fountain Place, 12th Floor, Suite 1200  
1445 Ross Avenue, Dallas, TX 75202-2733  
Phone: (214) 665-6444

## **IOWA, KANSAS, MISSOURI, NEBRASKA**

CAA 608 Enforcement Contact: EPA Region 7. Mail Code ARTX/ARBR, 901 N. 5th Street, Kansas City, KS 66101  
Phone: (800) 223-0425

## **COLORADO, MONTANA, NORTH DAKOTA, SOUTH DAKOTA, UTAH, WYOMING**

CAA 608 Enforcement Contact: EPA Region 8. Mail Code 8AT-AP, 999 18th Street, Suite 500  
Denver, CO 80202-2466  
Phone: (303) 312-6312

## **AMERICA SAMOA, ARIZONA, CALIFORNIA, GUAM, HAWAII, NEVADA**

CAA 608 Enforcement Contact: EPA Region 9. Mail Code A-3, 75 Hawthorne Street, San Francisco, CA 94105  
Phone: (415) 744-1305

## **ALASKA, IDAHO, OREGON, WASHINGTON**

CAA 608 Enforcement contact: EPA Region 10.  
Mail Code AT-082, 1200 Sixth Ave.  
Seattle, WA 98101  
Phone: (206) 553-1200







*ADVANCE TEST PRODUCTS*

**Miramar, FL**

**Telephone: (954) 499-5400 • Fax: (954) 499-5454 • Toll Free: (800) 327-5060**  
**[www.ProVaxAC.com](http://www.ProVaxAC.com)**